

ROAD ACCIDENT RESCUE

A European Perspective



by Paul Jerome
Regional Officer
Victoria State Emergency Service

Sponsored by:
Combined Emergency Services Foundation

July 1992

FOREWORD

This report is presented to the Chairman of the Board of the Combined Emergency Services Foundation, following the award of a study scholarship to investigate road accident rescue in Europe.

The original objectives of this study tour were to visit emergency services in Europe, to examine the following factors, with respect to road rescue in general and heavy rescue in particular:

The status of training;
The techniques used for training and rescue; and
The equipment used.

During the course of the tour I visited rescue services, which in all cases were fire services, and manufacturing and distribution companies in:

England;
Scotland;
France;
Holland; and
Germany.

In all cases I was warmly received. I also attended the First World Extrication '92 conference. This conference not only included an information seminar, but also an extrication competition, with representatives from seven countries around the world taking part. I also attended a basic tool maintenance course on Lukas rescue tools, while in Scotland.

Throughout all of the visits I was able to build a perspective on training, techniques and equipment, as used and produced in Europe. That information is presented in this report. The report is divided into a number of sections, each relating to visits undertaken and information on a similar topic. They are not necessarily in the order in which the visits took place.

In addition to the information presented in this report, in excess of 100 35mm slides and 3 hours of video footage were generated to support presentations on the material. Some six training videos on a range of subjects were also acquired, together with details of other training tapes. This will result in the production of a number of short training packages on specific topics.

As with all such investigative exercises, the information collected often exceeds that originally sought. This has certainly been the case in this instance, and I have attempted to detail as much as possible. In a number of instances, the information obtained will hopefully stimulate interest, discussion and possibly consideration of the review of organisational procedures.

Cover Photographs:

1. Gloucestershire Fire Rescue Service, England: Emergency Tender.
2. Wiltshire Fire Service Rescue Team competing at the 1992 British National Extrication Competition (Winners of the 1991 competition).

CONTENTS

| | |
|--|----------|
| Foreword | i |
| PART ONE WORLD EXTRICATION '92 | 1 |
| Chapter 1 Conference - The Management of and Operational Considerations at a Major Incident | 3 |
| Medical Aspects | 3 |
| Police Aspects | 6 |
| Rescue Aspects | 8 |
| Training Aspects | 9 |
| The American Perspective | 12 |
| Summary | 12 |
| Chapter 2 The Fire Service College, Moreton in Marsh, England | 15 |
| Chapter 3 The British Car Users Entrapment Extrication Society | 19 |
| Chapter 4 The First World Extrication Competition | 21 |
| Chapter 5 World Extrication '92, Trade Display | 27 |
| Hydraulic Tools | 27 |
| Air Tools | 28 |
| Hand Tools | 28 |
| Hazmat Control Products | 29 |
| Chapter 6 Training Material - Heavy Vehicle Rescue Techniques | 31 |
| Accident Types | 31 |
| Cabin Construction | 33 |
| Scene Assessment and Safety Considerations | 34 |
| Pneumatic Seats | 35 |
| Rescue Techniques | 37 |
| Technique One | 37 |
| Technique Two | 38 |
| Technique Three | 39 |
| Summary | 39 |
| References | 40 |
| Chapter 7 Training Material - Supplementary Restraint Systems | 41 |
| History and Development | 41 |
| Air Bag System Components | 42 |
| Operation of Air Bag Systems | 45 |
| Identification of Vehicles | 46 |
| Rescue Considerations | 47 |
| Guidelines for Rescue Personnel | 48 |
| Seat Belt Pre-tensioner Components and Operation | 49 |
| Identification and Rescue Considerations | 49 |
| Future Developments | 51 |
| Summary | 51 |
| References | 52 |

PART TWO RESCUE SERVICE VISITS 53

| | | |
|------------------|---|----|
| Chapter 8 | British Fire Service Visits | 55 |
| | Strathclyde Fire Service | 56 |
| | Greater Manchester Council Fire Service (GMCFS) | 57 |
| | Merseyside Fire Service | 59 |
| | Summary | 61 |
| Chapter 9 | Continental Rescue Service Visits | 63 |
| | Brigade de Sapeurs - Pompiers de Paris | |
| | Paris Fire Brigade - France | 63 |
| | Breda Brandweer | |
| | Breda Fire Service - Holland | 65 |
| | Tilburg Brandweer | |
| | Tilburg Fire Service - Holland | 66 |
| | Stadtfeuerwehr Erlangen | |
| | Erlangen City Fire Service - Germany | 67 |
| | Werkfeuerwehr Flughafen Nürnberg | |
| | Nuremberg Airport Fire/Rescue Service - Germany | 68 |
| | Summary | 69 |

PART THREE COMPANIES AND EQUIPMENT..... 71

| | | |
|-------------------|---|----|
| Chapter 10 | Company Visits | 73 |
| | Vepro - Air Bag Manufacturers | 73 |
| | Halmatro Industrial & Rescue Equipment | 76 |
| | Lukas Rescue Tools - FAG Kugelfischer | 77 |
| | Clan Tools & Plant Ltd | 79 |
| | Fluid Mechanics - The Technical Aspects of Hydraulic Rescue | |
| | Tools | 79 |
| | Summary | 81 |
| Chapter 11 | Hydraulic Rescue Tools | 83 |
| | German Standard | 83 |
| | French Standard | 84 |
| | Criteria | 84 |
| | Testing | 85 |
| | Tool Comparison by Brand | 86 |
| | Spreaders | 86 |
| | Cutters | 87 |
| | Discussion | 87 |
| | Summary | 89 |
| | References | 89 |
| Chapter 12 | Conclusion | 91 |
| | World Extrication '92 | 91 |
| | Rescue Service Visits | 91 |
| | Companies and Equipment | 92 |
| | Summary | 92 |

PART FOUR ANNEXES..... 95

| | | |
|----------------|--|-----|
| Annex A | British National Health System Medical Officer Appointments for a Major Incident | 97 |
| Annex B | World Extrication '92 Competition Judges Evaluation Form | 99 |
| Annex C | British Fire Services - Basic Rescue Equipment Carried | 101 |
| Annex D | Continental Rescue Services - Basic Rescue Equipment Carried | 107 |

LIST OF FIGURES

| | | |
|-------------|---|-----|
| Figure 1.1 | The M96 Motorway at the Fire Service College | 11 |
| Figure 4.1 | World Extrication '92 Competition | 23 |
| Figure 5.1 | All in one hand held combination hydraulic tool | 28 |
| Figure 5.2 | Nike laminated glass cutting tool | 29 |
| Figure 6.1 | Forward control cab with steel sub frame | 33 |
| Figure 6.2 | Design innovations in heavy vehicles | 34 |
| Figure 6.3 | Pneumatic seat mechanism | 36 |
| Figure 6.4 | Pneumatic seat | 36 |
| Figure 6.5 | Roof removal technique | 38 |
| Figure 6.6 | Strategic ramming and winching | 39 |
| Figure 7.1 | Supplementary restraint system crash sensors | 42 |
| Figure 7.2 | Ford SRS layout | 42 |
| Figure 7.3 | Ford SRS wiring configuration | 43 |
| Figure 7.4 | Crash sensor construction | 43 |
| Figure 7.5 | Saab crash sensor | 44 |
| Figure 7.6 | Mechanically activated air bag | 45 |
| Figure 7.7 | Steering wheel air bag module | 46 |
| Figure 7.8 | Passenger side air bag module | 47 |
| Figure 7.9 | Seat belt pre-tensioner | 49 |
| Figure 7.10 | Seat belt pre-tensioner mechanism | 50 |
| Figure 8.1 | Strathclyde Fire Service Heavy Rescue Vehicle | 56 |
| Figure 8.2 | Greater Manchester Fire Service RAR Training Course | 58 |
| Figure 8.3 | Merseyside Fire Service Emergency/Control Tender | 60 |
| Figure 9.1 | Paris Fire Service Rescue Appliance | 64 |
| Figure 9.2 | Erlangen City Fire Service | 67 |
| Figure 9.3 | Nuremberg Airport Fire/Rescue Service Technical Services Tender | 70 |
| Figure 10.1 | Vepro High Pressure Air Bag | 74 |
| Figure 10.2 | Quality Control at Halmatros | 76 |
| Figure 10.3 | Lukas Quality Assurance | 78 |
| Figure 10.4 | Cross Section of Lukas piston/cylinder configuration | 80 |
| Figure 10.5 | Series connected hydraulic tool system | 80 |
| Figure 11.1 | Force variation with spreader opening distance | 88 |
| Figure 11.2 | Cog driven spreaders | 89 |
| Figure 11.3 | Lever connected spreader | 89 |
| Figure 11.4 | Direct connect spreaders | 89 |
| Figure C.1 | Strathclyde Road Rescue Vehicle | 102 |
| Figure C.2 | Strathclyde Heavy Rescue Vehicle | 104 |

PART ONE:

WORLD EXTRICATION '92

While in England, I attended the Fire Service College at Moreton in Marsh, which played host to the three day World Extrication '92. The first day was a conference which examined management and operational considerations related to major incidents. The second and third days were devoted to the British and World extrication competitions respectively. During the whole event there was a large trade display and a number of workshop sessions. All of the information gathered is included in the various sections of this part of the report.

CONFERENCE**THE MANAGEMENT OF AND
OPERATIONAL CONSIDERATIONS AT
A MAJOR INCIDENT**

Introduction:

This conference consisted of two concurrent seminars with members of the emergency and medical services speaking on a range of related topics. Speakers generally put their comments in a 'Displan type' perspective, looking at the overall response, rather than specific details.

The definition of 'Major Incident' in Britain includes that of motorway collisions in heavy fog. This kind of incident can typically involve fifteen or more vehicles, multiple casualties and a number of fatalities. As a result, management and operational activities must be carefully planned and executed.

Medical Aspects:

The British approach to the medical aspects of a major disaster is to separate the tasks into two roles, that of treating the injured on one hand and, that of management on the other. The latter is not a role that just any medical person can assume, requiring a specifically trained doctor.

The treatment of casualties is carried out both by the Ambulance Service and Medical Disaster teams despatched from hospitals, in much the same way as in Australia. The role of the Ambulance Service in Britain is to provide initial treatment of injuries, prevent further injury and to transport to a critical care facility. The level of treatment provided is generally well advanced, being similar to paramedic level offered in Victoria. In some parts of Britain, medical treatment is also provided by General Practitioners, who attend the scene of motor vehicle accidents, often responding in their private vehicles.

The British Association for Immediate Care Schemes (BASICS) represents groups of doctors (each group forming one scheme), with designated response areas, that are available to provide immediate, on scene, care to casualties involved in major trauma causing incidents. The organisation promotes a management approach to the medical aspects of an incident which involves several casualties. It endorses a number of post graduate medical qualifications for its members including Diplomas in Pre-hospital Medicine and Immediate Medical Care, as well as short training packages in Advanced Cardiac Life Support and Advanced Trauma Life Support. The aim of the association is, by improving the training of care givers at the scene, to reduce 'The Therapeutic

Vacuum'¹. That is the time interval between the occurrence of the accident and the commencement of definitive care. This term has now been replaced by the much used American 'Golden Hour' concept, which suggests that a patient's mortality is significantly reduced if he or she can be delivered to a surgeon within one hour of the initial injury. For many trapped patients in Britain, as in Australia, this time is often exceeded. The British have therefore, extended the interpretation of the 'hour' by the provision of stabilising medical care at the scene.

To facilitate the management role requires both cooperation and communication, which is afforded, in Britain, through Joint Emergency Services Liaison and Planning Committees. Such a committee has representation of all emergency services and local authorities and is similar in nature to Victorian Municipal Emergency Management Committees.

Event Classification:

Dr Scott² describes the medical problems at a major incident (and these may be easily extrapolated beyond the medical arena):

1. To establish some form of order out of chaos. This involves both an initial triage, as well as the response to the special problems of individual patients, most commonly those suffering from entrapment.
2. To decrease mortality and morbidity in the casualties of the incident.
3. To allay the anxieties and fears in all those involved (casualties, witnesses, relatives and emergency service personnel).

As the Australian Counter Disaster College (ACDC) teaches, 'Over planning can result in under responding'. The British medical approach recognises this concept and attempts to classify the type of incident and respond accordingly. This is done using Rutherford's³ classification of major incidents as a guide. He classifies major incidents into:

Simple or Compound

Compensated or Uncompensated.

The straight forward, day to day, incident such as a road accident with two or three casualties, which produces an ordinary response from emergency services would be classified as Simple. A larger incident involving trapped casualties, rapid retrieval from the scene, and urgent surgical intervention would be classed as Compound.

Another way of looking at disasters is on the basis of the balance between the casualty load and the medical facilities available. Where the load is less than the capacity of the medical centre, the incident is a Compensated disaster, where the load exceeds the capacity, it is an Uncompensated disaster.

¹ This term was coined by Dr Kenneth Easton, who was Senior Medical Officer at Catterick Camp Army Barracks in 1949. He recognised that certain casualties would survive if their injuries were treated, during the pre hospital phase.

² Dr John Scott is Director and Course Organiser for BASICS Education. He is a member of the Mid Anglia General Practitioners Accident Service and attends, on average, 100 road accidents annually.

³ William Rutherford is a Consultant in the Accident and Emergency Department of the Royal Victoria Hospital in Belfast.

Medical Management:

Within the British medical system several appointments are made for the purposes of responding to a particular disaster. These are detailed in Annex A. The number of appointments made will be determined by the magnitude of the event.

This system, although apparently cumbersome on the surface, allows for escalation in response as the magnitude of an incident becomes apparent. BASICS promotes the concept that the first doctor on scene should assume the role of the Medical Incident Officer and the other roles should be delegated as support arrives. However in the heat of an actual incident, this is often not possible, and that doctor can on occasion be either 'sucked' in or physically dragged into the scene to provide treatment. It is also suggested that the first emergency service worker on the scene should commence an initial triage, regardless of his or her level of medical expertise (assuming at least some basic first aid knowledge), as part of the initial size up of the situation. This total medical approach, they believe, will result in the 'right' patient being transported to the 'right' hospital at the 'right' time.

In order to facilitate this 'right' approach, the British teach that it is necessary to have an understanding of the sequence of events that produce injury, and the subsequent reaction of the body, this will allow a structured approach to rescue. To assist this process, injury prediction methods are described. The preferred one is a four point approach:

1. The type of accident may give important leads to the input of energy.
2. The vehicle may show signs of damage indicative of the risk of, or general severity of, injury or specific damage.
3. The mechanism of injury may allow a link to be made between vehicle damage and occupant injury.
4. Patterns of injury may be recognised such as the well known pair of head injury and neck fracture.

This in turn will make more obvious and accurate the methods employed for handling the patient generally.

Following extrication, the patient has to be transferred from one group of professionals to another. With the physical movement there must also be a transfer of information, which in the past has been anecdotal and ad-hoc. Dr Snook⁴ has suggested the subject must 'come of age' and be disciplined. He described a simple system which has been implemented in several areas in Britain and is now proving to be a template with which the transfer of information is clear, concise, reliable and relevant, and in which both sides work to agreed terms and definitions. That system describes a road accident in terms of:

| | |
|------------------------------|-----------------|
| Transfer of energy | Frame integrity |
| Relative direction of impact | Intrusion |
| Aspect of vehicle damage | Contact points |
| Focus of force | |

Despite this apparently well organised medical approach and system for classifying disaster types, injury prediction and road accident description, it is interesting to note that there is no national British standard for triage cards, with several different types in use. Britain also appears to suffer a problem of 'Mobilising the right number of

⁴ Dr Roger Snook is Director of Accident and Emergency Services at Royal United Hospital, Bath. He is one of Britain's leading experts in road traffic accident casualties, and was responsible for establishing Britain's first medical 'Flying Squad' in 1965.

appropriately trained responders' to the scene of an incident in a timely manner. Concerns similar to those in some parts of Victoria, have been expressed by Fire Service rescue staff, in relation to a lack of concurrent turn out. Very often in Britain, until the arrival of medical care, rescue personnel have total responsibility for patient care in the early stages of a rescue.

A survey of 100 British rescue personnel identified five principal concerns under the heading of Casualty:

- Assessment
- Deterioration
- Practical First Aid
- Spinal Injury
- General Handling

To put these responses into context, it is necessary to understand that there is strong feeling among many Fire Services personnel that the first aid training offered is inadequate. This must be weighed against the cost involved. Currently the cost of a fatal accident in Britain is set at £610,320⁵.

Indications are that limited research is being undertaken in Britain in the field of road trauma, from various perspectives. Snook suggests that for progress to be made the following course of action should be pursued:

"Research, on which is based more relevant training, must involve integration between working disciplines. Information must cross boundaries, and a study of team dynamics will ensure the resulting practice of rescue is performed in the safest and most efficient manner for the sake of the patient, whom we all serve."

On the basis of this comment it would seem fairly reasonable to suggest to Dr Snook that a Victorian style 'Systems Approach' would go a long way to answer some of his dilemmas.

Police Aspects:

Based on the information amassed from the conference, it would appear that the Police Forces in Britain, have no particular legislated responsibility to undertake the coordination role at a major incident, as their Victorian counterparts do under Displan and the Emergency Management Act. The British do, however, carry out this role by common law as part of their charter to protect life and property.

At a major incident the British Police see their role as one of 'Mobilising and organising emergency and support services'. To effect this, local Police take an active part in Joint Emergency Services Liaison and Planning Committees and aim to generate their own internal plans to address the Police response to a major incident such as a multi vehicle incident on a motorway. The key concept of 'Flexibility in planning' as espoused by ACDC, is well recognised.

⁵ British Transport and Road Research Laboratory, 1988. This figure was unsubstantiated, but I presume it to include costs associated with initial response, all facets of treatment and investigation of cause, as well as the salaries of all personnel involved in these various stages.

Skeletal plans are developed to address the key issues of:

- Saving lives
- Coordination of other emergency and support services
- Protection and preservation of the scene
- Safety of other traffic using the road at the time
- Monitoring a flow of traffic in preference to using diversion routes
- Collating and disseminating information
- Investigating the scene
- Restoring normality at the earliest opportunity.

These issues are categorised for planning purposes into three separate areas of activity:

1. Scene Management
2. Investigation
3. Incident Room.

It is interesting to note the British approach to traffic diversion, as described in the key issues above. Given the relatively small size of the country, and the large number of alternative road ways available in most areas, their 'last resort' approach to traffic diversion is unusual.

As an example of this system, the Thames Valley Police⁶ have developed a major traffic accident plan. This incorporates 'Action cards' which are carried by each patrol car and identify specific tasks to be carried out. The Incident Commander (equivalent to the Police Commander in Victorian Displan terminology) can then delegate duties to individual cars by referring to specific Action Cards. This results in reduced radio traffic.

The whole incident is generally divided into sectors especially when large, and each sector is headed by its own commander. To assist the command structure, a colour coding system is used. Section commanders are known as 'Bronze', the Incident Commander is designated 'Silver' and the equivalent to Victoria's Incident Controller would be known as 'Gold'. Under the Thames Valley system, this person would operate from the 'Incident Room' (similar to an Emergency Coordination Centre), and the appointment of 'Gold Commander' is only made if the magnitude or duration of the incident warrants it.

To assist this plan, a three layer communications network is established:

1. A dedicated VHF channel is made available to control all matters other than the accident ground (eg. logistics requests, traffic control, etc.).
2. The accident ground is controlled by various UHF frequencies all reporting back to the control vehicle. The number of channels used will depend on the magnitude of the incident and the number of sectors involved.
3. Inter service radio liaison is also being made available, although this requires a separate base station.

Further support may be made available, should the Bronze and Silver commanders deem necessary, in the form of an Incident Room with or without the Home Office

⁶ The Thames Valley includes some 193 miles of Motorway and covers several Police districts. The Major Traffic Accident Plan system they have developed is the subject of a copyright, and is under consideration for marketing.

Large Major Enquiry System (HOLMES) computer system. This computer data base not only incorporates the capability of the Australian Red Cross administered National Registration and Inquiry System (NRIS), but also may be used for the logging and tracking of evidence in major incident investigations. It was successfully used in the Lockerbie air disaster to record the locations of the 270 persons killed, as well as the many thousands of pieces of wreckage, luggage and body parts found, recovered and subsequently transported.

To put HOLMES in perspective, the Lockerbie incident covered an area of 845 square miles (2190 square kilometres), which was divided into 11 differently sized sectors, each of which had a Bronze Commander and 25 Police personnel generating data in relation to evidence collected, locations and descriptions. One would think that with such an illustrious name, not only could the program collect the data, but using 'Elementary deduction' solve all the unknown questions!

Rescue Aspects:

In Britain, road, and general rescue services are provided by the Fire Brigades. Each municipality, has its own Brigade, and all are governed by common guidelines laid down by the British Home Office. While many brigades have their own training facilities, they also have access to establishments such as the Fire Service College.

The level of interest in rescue varies considerably from one brigade to the next. This principally stems from the fact that the only organisation in Britain with a legislated rescue responsibility is the Royal Life Guards Society (Coast Guard). The Fire Services, despite the expectation of the community, are only obliged to provide fire protection services. Some Fire Services are, however, very pro-active, and have gone as far as changing their name to 'Fire and Rescue Service'. It is brigades such as these that take an active role in training, planning and preparing for the inevitable 'Major Incident' that will occur in their area.

Liaison is encouraged and facilitated through involvement in local Joint Emergency Planning Committees, which have representation from each of the emergency services, as well as the local County Emergency Planning Officer⁷. As an additional function this group forms a Major Incident Planning Group. The purpose of which is to develop Response Plans to identified potential major incidents. Once developed the plans are regularly tested in both desk top and operational exercises. As with the Victorian situation, the level of interest and motivation to complete such tasks varies from one county to the next.

Fire Services are encouraged to develop their own internal response plans, as part of the overall plan, to the identified hazards in their area. Under such plans, when the Service responds to a major road accident, for example, an inner cordon is established around the accident site. A communications link is formed between the Forward Control Point (FCP), at the scene, the Incident Control Point⁸ (ICP) and a Major Incident Control Point (MICP), which is similar to an Emergency Coordination Centre. In each case, close liaison is maintained with the Police, which in Victorian terminology, would be considered the Combat Agency. By maintaining liaison at each level, the Fire Rescue service can link in to the Police (colour coded) commanders as required, to further resource their needs, and keep Police Commanders well briefed. The need for this goes beyond a simple liaison. As is the Victorian situation, Police take on the role of Media

⁷ A County Council appointment that performs a similar role to the Victorian Municipal Emergency Resource Officer (MERO).

⁸ The British concept of a FCP and an ICP both in the field, only stems from the fact that often large incidents are divided into sectors and each area of operation has its own FCP. The FCPs then all coordinate through a single ICP which may be at some distance away, depending on the size and nature of the incident.

Liaison, for all incident types, and regular inter service briefings are held. At the conclusion of a major incident, both single service and inter agency debriefs are conducted.

From an operational perspective, the Fire Rescue Service is encouraged to establish an assembly area adjacent to the scene of the incident, for all of its personnel and equipment to rendezvous before being tasked.

Despite this apparently well planned management approach, a survey of 100 Fire Service rescue personnel identified the following principal concerns under the heading of rescue:

- Causing more harm to the casualty
- Techniques
- Modern car design
- Team work
- Time

These concerns support the feeling among Fire Service rescue personnel that there is a need for a greater amount of structured training in the field of practical road accident rescue.

Training Aspects:

As described earlier, the British Fire Service has no legal obligation to attend road accidents for the purpose of rescue. Given this, the budget of many individual Fire Authorities, makes no provision for expenditure in either training or equipment, despite rescues being the fastest growing area of most Services' business.

The Fire Service College (FSC), and some British Fire Services (generally those with a more interested Chief Officer), are taking on this problem directly. Not only are they developing training programs to address the 'hands on' problem of rescue skills for the operator, but the FSC is also promoting the need for inter agency training. Assistant Chief Officer Norbury⁹ describes the level of liaison between services as varying from very good to non-existent.

"It is often borne out of mutual ignorance and misguided omission of multi-agency training."

The FSC not only promotes inter agency training, but teaches that at a major incident, the first crew on scene irrespective of the emergency service should not become involved but take on a management role and assess the situation, determine assistance required and report back¹⁰. Evidently this does not always happen, and often members of one agency are not fully aware of the other agency's roles, responsibilities or priorities.

At Fire Service level, most brigades invite guest lecturers from other agencies to recruit training courses in order to give an overview of that agency's role. This however, is often the limit of inter-service training and understanding of one another's roles and responsibilities. The efforts of the FSC to address this dilemma include realistic multi

⁹ ACO Anthony Norbury is head of the School of Operations at the FSC. He has 28 years experience in the British Fire Services.

¹⁰ Although no indication was given, the approach being fostered by the FSC falls within the AIIMS/NIIMS (Australian/National Inter-agency Incident Management System) concept for emergency management.

vehicle motorway exercises in which all agencies are invited to participate. Despite this, Norbury reports:

"...there are still people within ALL emergency services who do not appreciate the benefits of inter-service training."

In an attempt to overcome this 'Inter-agency' problem, the suggestion of reducing the number of agencies by take over bids (eg. Fire Services taking on the Ambulance role) has been mooted. In some areas of Britain, Police vehicles carry hydraulic rescue tools, but their members are untrained in their use. This would appear to suggest, with the exception of isolated brigades and the FSC, that there is little or no inter-agency training or exercising, and certainly nothing in the form of a systematic and comprehensive approach to incident management.

To put an operational perspective on the training debate, very few brigades are running formal training programs in rescue. The FSC, however, offers a range of courses up to a 3 week RAR instructors course. Such courses not only recognise the need to provide a competent skills level but also address the ever changing technology associated with the motor vehicle industry.

Divisional Officer Henderson¹¹ describes the areas of training which need addressing as:

- Knowledge of vehicle construction
- An appreciation of the effects that extrication processes will have on the structure of vehicles
- Stability of vehicles
- Rescue techniques
- Casualty handling techniques
- Topographical knowledge of road systems and access points
- Dealing with hazardous loads
- An awareness of vehicle features posing potential hazards (such as hydraulic struts, suspension systems, stored energy cutting, super hot catalytic converters and supplementary restraint systems)
- Equipment maintenance and testing.

The FSC courses also provide valuable training for supervisory officers (ie. Rescue Commander or Team Leader) at the scene. In this respect, the training is similar to the Victorian Combined Emergency Services training, offering a 'Systems Approach'. Henderson describes:

"They (Rescue Commanders) must develop a systematic approach to incidents beginning with the approach and positioning of appliances, then making a careful assessment of the incident..."

Factors the FSC promote for a rescue commander to consider include:

- Estimating current capabilities of crew and supplementing if necessary
- Ensuring crew safety
- Prioritise tasks and delegation
- Organising casualty handling areas
- Fatality identification system
- Water supplies and fire fighting media
- Liaison with other emergency services

¹¹ Divisional Officer Brian Henderson is Head of the Road Traffic Accident School at the FSC.

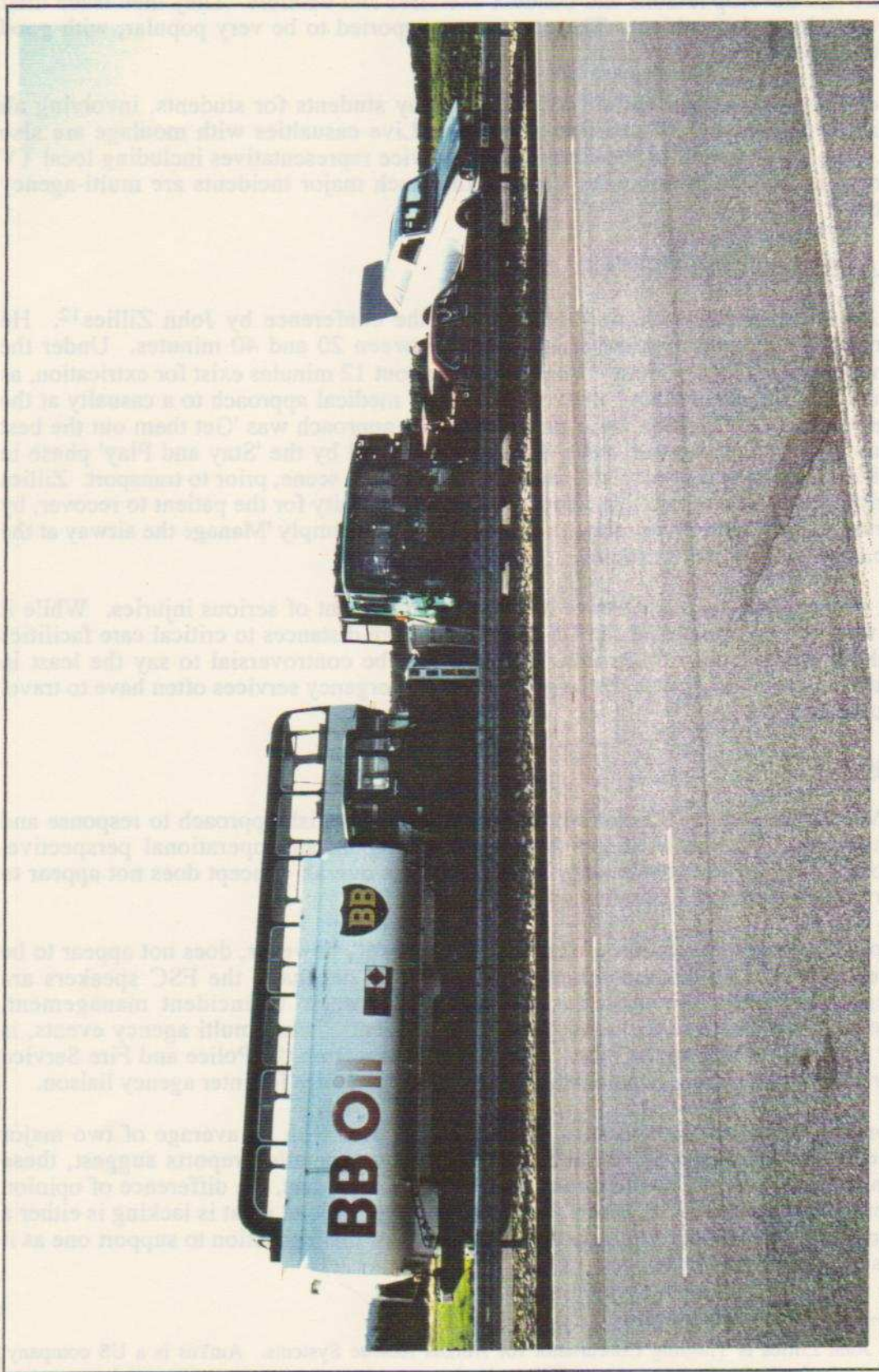

Figure 1.1: The M96 Motorway has been specially constructed on the grounds of the Fire Service College and provides an ideal training ground for realistic multi-vehicle road accident rescue exercises.

All of these concepts are taught on the RAR instructors course using 'student centred' educational techniques. That is, students are encouraged to research a particular area, prepare and develop lessons and conduct exercises and debriefs. They then teach their fellow students that subject. The courses are reported to be very popular, with good results obtained.

The exercises described earlier are presented by students for students, involving all forms of vehicles and all possible scenarios. Live casualties with moulage are also used. The involvement of local emergency service representatives including local TV reporters is used to promote the concept that such major incidents are multi-agency events.

The American Perspective:

The American perspective was described at the conference by John Zillies¹². He described the average extrication as taking between 20 and 40 minutes. Under the much promoted 'Golden Hour'¹³ concept, only about 12 minutes exist for extrication, as a result, this has necessitated an evolution in the medical approach to a casualty at the scene. Prior to the Golden Hour philosophy, the approach was 'Get them out the best we can, and then scoop and run'. This was followed by the 'Stay and Play' phase in which much time was spent stabilising casualties at the scene, prior to transport. Zillies described the new approach, to allow the best opportunity for the patient to recover, by ensuring a one hour delivery time to the surgeon, as to simply 'Manage the airway at the scene, and treat the rest en route'.

This, clearly, is a very aggressive approach to treatment of serious injuries. While it may well be appropriate for the US situation, where distances to critical care facilities are short and response times low, it is likely to be controversial to say the least in Australia, particularly given the large distances emergency services often have to travel to incident scenes.

Summary:

The World Extrication '92 conference presented the British approach to response and management of major incidents from both a Displan and operational perspective. Although some of the terminology is different, the overall concept does not appear to differ greatly from the Australian approach.

The practical implementation of the 'Displan concept', however, does not appear to be as well accepted as the theoretical approach. On one hand the FSC speakers are strongly promoting the need for a 'Systems approach' to incident management, suggesting that this and the concept of such incidents, being multi agency events, is sadly lacking. While on the other hand, the speakers from the Police and Fire Service are promoting an incident management system that provides for inter agency liaison.

According to one of the speakers, Britain has to deal with an average of two major incidents per year. As media and subsequent more detailed reports suggest, these appear in general to be handled reasonably well. Given this, the difference of opinion expressed by the various speakers would tend to suggest that what is lacking is either a national body to propose a standardised approach, or the legislation to support one as it exists in most of Australia.

¹² John Zillies is Training Coordinator for Amkus Rescue Systems. Amkus is a US company, producing hydraulic rescue tools. Zillies also has extensive experience as rescuer and paramedic.

From an operational perspective, the most pro-active training in the multi-agency arena appears to be coming from the FSC, by way of their exercises in which they involve other local agencies. This combined with their desire to incorporate new ideas and approaches such as the American experiences, and the lobbying of vehicle manufacturers to improve their designs, is likely to see an overall improvement in the level of understanding, interest and ultimately patient care offered.

13 Under the Golden Hour concept, the patient has approximately sixty minutes from the time of the accident to be located, treated, extricated, transported, stabilised by the emergency department and delivered to the surgical team.

THE FIRE SERVICE COLLEGE

MORETON IN MARSH ENGLAND

The Fire Service College (FSC), at Moreton in Marsh, England, is arguably the finest facility in the world for practical fire & rescue training. Having been in existence for over 25 years, the FSC is well established and trains over 7000 individuals a year in fire, safety and emergency skills. In over 250 courses each year, training ranges from practical fire fighting and rescue skills to senior command and leadership. In all the practical courses the college creates learning experiences for the student.

The college is built on an ex-RAF base, has facilities for over 500 residential students and utilises the old runways for its various training grounds. Full scale buildings which are set alight during exercises include: industrial units; a house; a five storey shopping complex; a 4000 tonne dry cargo ship with engine room, cargo hold and bridge situated in its own lake with dockside and warehouse; a large chemical plant with storage tank, cracker unit, flange and screen and LPG area; and an aircraft.

Besides the courses for fire fighting, industrial safety, the Merchant Navy and command officers the FSC conducts a Road Traffic Accident Instructors course, over three weeks. The course is designed for personnel required to give practical instruction in road accident rescue (RAR) and who have a level of command experience or similar seniority. The aim of the course is to enable students to successfully devise and undertake training sessions in RAR techniques and equipment. The course covers:

| | |
|----------------------|--|
| Casualty care: | Methods of sustaining life and rendering first aid. |
| Teaching Methods: | Both theory and practical. |
| Equipment: | Practical exercise using extrication equipment. |
| Procedures: | Updates on the latest procedures adopted by all emergency services. |
| Stability: | Methods of stabilising both casualties and vehicles at accidents. |
| Practical Exercises: | Realistic training exercises covering all types of incident using trucks, tankers, buses/coaches and other vehicles. |
| Casualty Simulation: | Casualty make up and simulated injuries. |

The course is delivered by senior officers and visiting lecturers with specialist expertise, through a series of lectures, discussions, practical exercises, project work, counselling and tutorials. Students are encouraged to research a particular area, prepare and develop lessons, and conduct exercises and debriefs. They then teach their fellow students that subject.



A road traffic accident on the College motorway, recreated using vehicles from the on-site scrapyard



The extensive railway system includes embankment, level crossing, diesel engine and rolling stock

- Fireground facilities
- Indoor teaching facilities
- Social, sporting and accommodation facilities

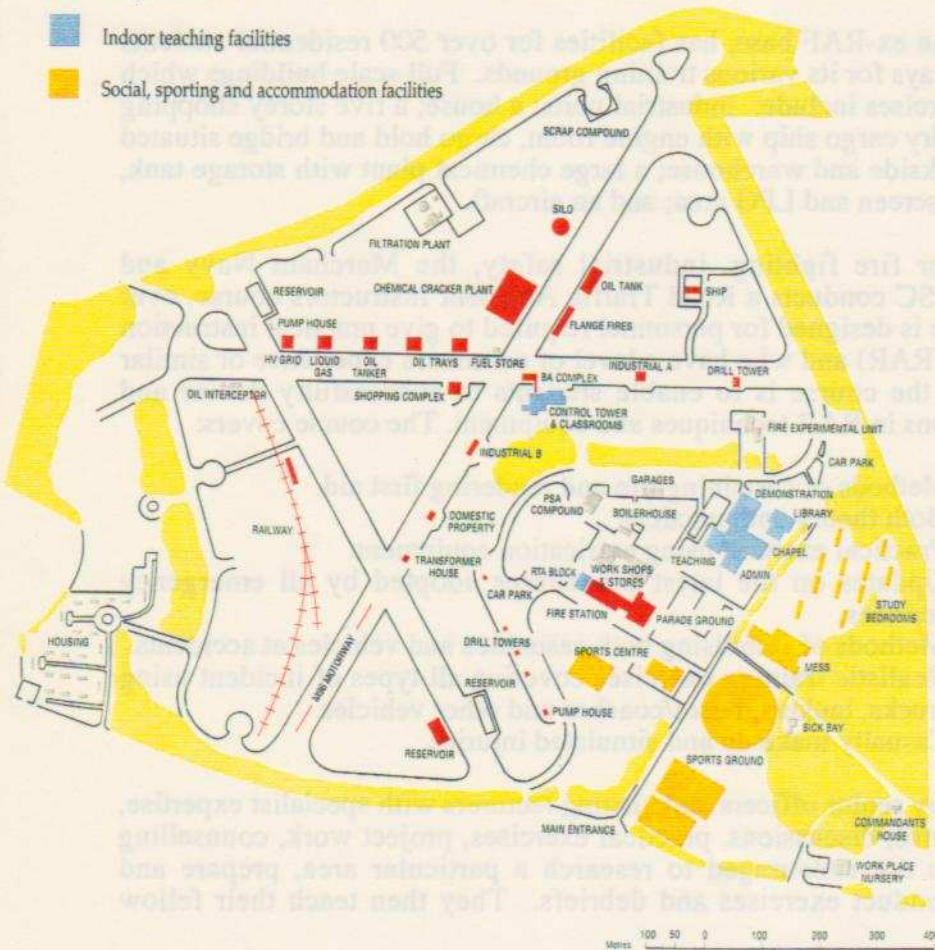

The breathing apparatus centre has a three storey fire house and a search and rescue centre



An exercise at the shopping complex

THE FIRE SERVICE COLLEGE · MORETON-IN-MARSH · ENGLAND

To enhance the practical delivery of road accident rescue training, the FSC also has a section of British motorway and full railway line complete with carriages, locomotive and railway station to simulate all forms of incident type. The array of vehicles available includes many makes of modern¹ cars, road tankers, semi trailers and buses, as well as cargo rail carriages including those carrying nuclear material and the like. The college has a full time staff of civilians employed to set up such exercises and spends in the order of \$100,000.00 per annum on the purchase of wrecked vehicles to facilitate such training.

It is generally accepted, at least in Britain, that the FSC is a centre for excellence. As a result, many manufacturers of fire fighting and rescue equipment, lend the College equipment in order to take advantage of its name. They then use this as an endorsement of their product. The benefit to the FSC for this is that it purchases very little of the equipment and appliances it uses for training. Most is supplied on a trial or loan basis.

It is interesting that despite the fact that the FSC attracts students from over 75 countries, including Australia, no one from Australia has participated on a practical course such as the RAR Instructors course to date.

In addition to the above, the FSC has already developed the first (in Britain) Bachelor of Engineering degree in Fire Safety, and is developing an advanced rescue course. This will be a two week course involving both theory and practical components and will culminate in a one day full scale emergency incident.



¹ The term 'modern' is used to indicate up to date vehicle types (ie less than 10 years old), not old wrecks from the local tip, as is often the case in similar training in Australia.

THE BRITISH CAR USERS ENTRAPMENT EXTRICATION SOCIETY (C.U.E.E.S.)

CUEES played host to World Extrication 92, by taking on the responsibility for organising what they described as a learning symposium and extrication competition.

CUEES was formed in September 1989, and is a society of Emergency Service Personnel with a vested interest in the rescue of accident victims trapped within the confines of vehicle wreckage. CUEES promotes the correct methods of extrication and techniques in relation to immediate care and invasive life support, training and enhancement. To achieve this, CUEES aims to provide an environment in which learning and idea exchange can take place between experts from all around the world. Such environments include extrication competitions and learning symposia, as well as proposed training packages and qualifications in the form of a Diploma of Extrication Studies.

CUEES founders Mike Akers and John Drudge (both London Firefighters) discovered that British standards were far below those of places such as America, Australasia and some countries of Southern Africa in extrication thinking, training and technology. CUEES was born of the frustration resulting from no legislated rescue responsibility and therefore little or no funding to the Fire Services to provide training or equipment for rescue. This frustration would appear, once again, to point to the lack of an integrated (Systems Approach), multi-agency approach to training for major motor vehicle incidents in Britain.

At present CUEES has contact with extrication personnel in Australia, Russia, New Zealand, Hong Kong, South Africa, Ireland, Canada and the United States. It is also currently developing training literature on:

- Risk management;
- Rapid access and intervention; and
- Space making techniques in relation to traumatic injury and controlled release management, ie. reducing the incidence of crush syndrome.

CUEES also supports the concept of teaching rescue personnel Advanced Trauma Life Support to assist and augment Ambulance Service crews in major incidents, or when they are unavailable. Such training would include intubation and infusion skills. It should be noted that in Britain, in almost all cases the rescue function is not provided by a volunteer service. To implement such a policy in Australia, outside major population centres would have many and significant difficulties.

Despite highlighting that in general British extrication technology is probably somewhat behind that of Australia, the concept of CUEES as an information exchange organisation has appeal. A number of the Australians present during World Extrication '92 expressed interest in CUEES and moves are currently being made to establish a similar body in this country.

In addition to the literature and activities described above, CUEES produces a quarterly magazine with content from around the world. This serves to expand the knowledge base of all who subscribe, providing a fresh and different perspective on the problems all rescuers face. Establishing a similar organisation in Australia I believe, can only further the development and expand the knowledge of extrication in this country. I would recommend all personnel interested in extrication, support such a proposal, and I would be happy to provide further information on request.

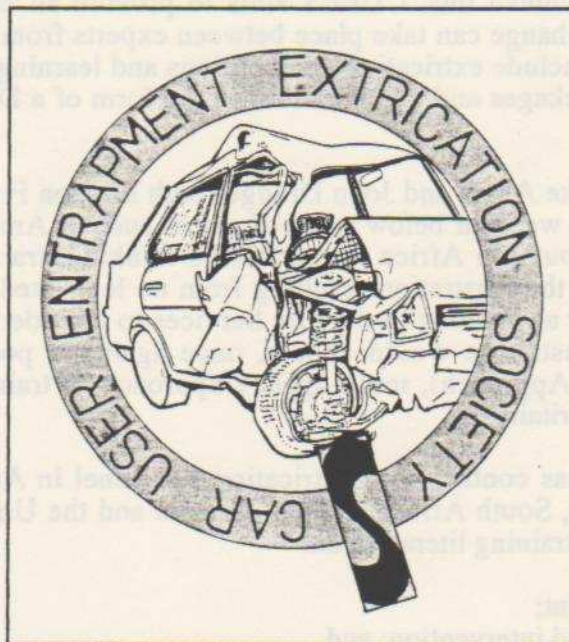

THE FIRST WORLD EXTRICATION COMPETITION

Following the conference held on the first day, the second and third days of "World Extrication '92" were devoted to the British and international competitions respectively.

The concept of an extrication competition, of this type¹, started in Canada, from the Office of the Fire Marshall. The aim was to improve the standard of skills of extrication personnel, by allowing them to gain experience and share ideas with fellow professionals from different organisations. The first extrication competition was held in Canada in 1985, and quickly spread to the United States. In 1989, two British Road Traffic Accident Instructors visited the Canadian competition, and returned to Britain to establish CUEES and the competition. In 1992, the competition expanded for the first time to a world competition, with teams representing Britain, Ireland, USA, Canada, Holland, Virgin Islands and South Africa taking part. Observers and road accident rescue instructors were also present from Sweden and Australia. Over the two day period, a total of 18 British and 12 international teams competed.

The extrication competition consisted of a simulated road accident involving an accident damaged vehicle with person(s) trapped. Teams consisting of five personnel², were given 20 minutes to extricate the casualty(ies). Three different scenarios were used:

1. A single vehicle, on its wheels.
2. A single vehicle, on its roof.
3. One vehicle on its side, supported by leaning its chassis against another intact vehicle, in 'T-bone' configuration.

In each case, all vehicles were complete, and essentially intact, except for damage caused by the accident (eg. windows smashed, etc.). This was usually inflicted by way of a front end loader or similar appliance!

The only other variation between one situation and the next, was that the world competition required extrication of two casualties, while teams competing in the British national competition were only given one casualty to extricate. In all scenarios, live casualties were used.

¹ It should be noted that this form of competition is solely restricted to road accident extrication, and does not compare with competitions such as those which have been conducted by the Fire Services or SES's in Australia for many years.

² Each team was obliged to have a designated team leader (who was identifiable) and usually also included a medical care specialist, such as a paramedic.

To facilitate the process of the competition, the following procedures were used:

- * Each team leader (TL) was asked to 'draw lots' for both the order of competition and the scenario presented, but were given no indication of the scenario type they had chosen.
- * Teams were given time, prior to their scenario being set up, to select and layout their rescue tools and equipment. They were able to choose from every brand and appliance on the market, which were supplied by the traders on display at the conference. A selection of other hand tools, blocks, and sundry equipment was also available. No specific rescue vehicle was supplied. Tools were laid out in a designated area.
- * Each team, once equipment had been selected, was removed from the area while their chosen scenario was prepared. They were then delivered back to the scene in a light tight van, so that no pre warning of their situation was given.

Teams were awarded points, by judges, according to their skill, expertise, casualty handling and knowledge.

The criteria for becoming a judge in such a competition, includes a minimum 10 years operational experience in extrication, as well as an enthusiastic desire to improve both his/her own knowledge, and that of others. A minimum of three judges are used to mark each team, who must not confer with one another during an event. A judge's neutrality is maintained, by ensuring he/she does not become involved in assessing a team from their own organisation. Judges are rotated through out the competition to ensure a high degree of concentration is maintained.

The judging is marked in four areas:

Coordination & Control³

Safety Aspects

Extrication Technique

Completion of Task

'Coordination & Control' includes assessment of the TL's initial size up of the situation, and circumnavigation of the scene. It evaluates his briefing of the team, consideration of safety aspects and stabilisation (both of the vehicle and the casualty). The judges look for controlled communication between the TL and members. Marks are awarded for an obvious plan of action, and the control of that plan, by a TL who stands back and looks at the 'Bigger picture'. Good early assessment leading to the production of 'A hole to fit the casualty', rather than trying to fit the casualty into the existing hole, is well rewarded.

The judges brief includes strong consideration for knowledge of the correct operation and most efficient use of the tools employed. This not only includes both the techniques used and the subsequent effect on the casualty and other team members, but also the team's demonstrated knowledge of vehicle design and construction, by the choice of technique used. Safety at the scene weighs heavily on the marking, taking up as much as 40% of the available score. Safety of the casualty, the crew and the scene are examined closely, with a particular emphasis on safe working practices.

³ It is interesting to note that despite the fact that this section relates to the Command component of activity, it is surprisingly missing from the British title!

In general, the performance of teams in the international competition was of a higher standard than that of the British teams. Particular emphasis was paid by all teams to vehicle stabilisation, with 'Flat tyre blocking'⁴ the preferred technique for vehicles still on their wheels. British teams appeared to be quite concerned about a synchronised approach to release of air from either both front or both rear tyres together. This was less of a concern to the international teams. In many cases, however, the actual placement of blocks or cribbing under the chassis failed to properly support and stabilise the vehicle, this therefore made the synchronised approach necessary to ensure the casualty had a 'Less bumpy' ride down! Quite obviously, it had little benefit, if the vehicle was not stable at the end of the task.

It is quite interesting to note, that flat tyre blocking receives reasonably wide spread use in the 'Road rescue enthusiastic' British brigades, considering also that the equivalent of the Accident Investigation Section in Britain, pays particular attention to tyre pressures as part of their investigations. These facts therefore, when combined, point once again to an apparent lack of communication between services.



Figure 4.1: A British Team competes in World Extrication '92 under the watchful eyes of four independent judges.

The competition may be reasonably compared against the Victorian Combined Emergency Services standard of assessment for accreditation of RAR units in order to provide a gauge for relative performance of overseas rescue units and Victorian ones.

⁴ Flat tyre blocking, that is the use of wooden blocks or jacks to support the vehicle by chassis, while the air is removed from the tyres, is commonly used in many countries as means of stabilisation of vehicles.

The following is a summary of some of the more non-standard or significantly different techniques or pieces of equipment used by various teams at the competition:

Communications: Several teams made use of radio communications between their TL and other team members. Some teams used hand held radios in harnesses, which created several problems with feedback due to their close proximity to one another. It also failed to perform in the way intended, which I presume, was to reduce the need to shout at the scene in order to be heard over the noise of generators, powered hydraulic pumps, etc. Some teams, were more 'high-tech', with voice activated radio systems fitted into their helmets. Such teams usually operated with open face motor bike type helmets.

Roof Removal: Without exception, every team presented with an upright car on its wheels from which casualties were to be extricated, removed the roof. This shows that the American teaching of this technique has been widely accepted. That is, making no attempt to minimise damage in the interests of an expedient extrication.

Patient Protection: As is common practice around the world, patients need protection during dangerous procedures, such as cutting of pillars, removal of doors, etc. A number of teams elected not to use the familiar tools of either a blanket, an uninflated air bag, or a wooden back board. They instead, opted to use a section of clear perspex sheeting, with hand holes cut in, similar to a Police riot shield. This had the advantage of allowing the rescuers and medics to maintain observation on the casualty during the procedure. The disadvantage is that the casualty can also see the manoeuvre, which may cause undue stress.

Team Leader Identification:

In general team leaders were not readily identifiable, with their uniform, blending in with the remainder of the rescue crew. In some cases, helmet markings were different, but this was not consistent and was usually an in service arrangement. Some teams worked in overalls, specially for the competition, but their normal turnout clothing, as with the other teams, is standard Fire Service issue, thus causing an even greater blending at the scene with other Fire Service personnel. The use of tabards has been developed.

Backboards: The more competent teams made full use of both half and full length spinal back boards for care of their patients. This along with any other spinal (particularly cervical) immobilisation devices, such as the Kendrick Extrication Device (KED), is strongly promoted by the US rescue services.

Tool Usage: The use of tool staging areas appeared popular with many of the international teams, as did utility belts for selected members of the team. These belts contain small hand tools such as pliers, cable cutters, etc. and in one case included a roll of tape for masking sharp edges.

Techniques: Sabre saws were used in preference to hydraulic cutters by some teams for cutting wide 'C' pillars. This combined with the use of high tensile flexible blades and lubricant, generally proved to be more efficient than other methods.

A number of the vehicles provided for the competition were coupés. This resulted in most teams faced with them performing third door conversions⁵ to facilitate removal of the casualty in as flat a position as possible.

Techniques used to restrict stored energy effects during the release of doors, such as 'bumming the door' were not employed. Such loose objects, if required, were secured using rope, but in general a hinge side first approach was used to reduce the likelihood of the door moving excessively.

Comparing the performance of the British teams this year, with the report of the head judge from the last year's British competition has highlighted a number of factors. Not only has there been an improvement in standards, but also what I perceive to be a dangerous trend in performances at the competition. That is, to perform to the competition requirements, rather than adopting a realistic approach to an incident. While this may not be very significant in the competition environment, if it spills over to the operational setting, it has the potential to cause a serious distraction to the real purpose of the rescue crew. One such example was a reference to safety considerations by the 1991 head judge⁶ to:

"....Breaking glass and leaving large amounts laying around, to be knelt on, casualties dragged through and to enter open wounds, etc....."

This appeared to have been taken in and heeded by the British teams competing this year, in some cases, to ridiculous lengths. Instead of attempting to develop or learn new techniques for glass removal that will reduce the amount of spillage, several teams appeared to be quite happy to produce the same result, and then commit a team member to use a dust pan and brush to sweep up the glass. This was, however, not indicative of the performance of all British teams, with the winner of the world competition, judged by international judges, being a British team. To one team's credit, a vacuum cleaner was used.

The judges evaluation form for the competition is included at Annex B. Although more simple than the evaluation process used for Victorian RAR accreditation purposes, it allows reasonable comparison of the performance of teams in this competition with that of VICSES units⁷ during the skill demonstration phase of the Combined Emergency Services RAR assessment process. Doing so suggests, I believe, that the base line standard in Victoria, is significantly higher than in Britain. At the other end of the scale, are those VICSES units which set the standards for others to follow. It is, of course, conjecturing to try and place them in the international competition and predict a result, however, I believe it reasonable to suggest they would have scored in the top four.

⁵ A third door conversion is the name given to a technique used to cut an opening into the rear side wall of a two door car. That is to create an opening or third door between the 'B' pillar and the rear wheel arch. The process includes removal of the 'B' pillar.

⁶ Both the 1991 and 1992 head judge was Syd Farley, who has 23 years experience in the Fire and Rescue Service. He is head judge of the British section and is responsible for the standard and training of all British judges.

⁷ Comparison has been limited to VICSES road rescue units, as the author does not have sufficient first hand experience of the performance capabilities of other services to comment with authority.

CUEES makes it quite clear that the extrication competition is one of good working practices. It is a competition designed to improve everyone's awareness, ability, professionalism and competence in the science of extrication. It is a competition by name and intent, not just a seminar and series of demonstrations of techniques. Unlike other competitions, whereby teams attempt to keep secret their techniques and developments, this competition promotes the open exchange of knowledge, ideas and attitudes. The purpose of this is to ensure that the real winner is always the casualty being extricated in the real incident.

release of doors, such as...
employed. Such force objects, if required, were secured using...
top, but in general a hinge side first approach was used to...
reduce the likelihood of the door moving excessively.

Comparing the performance of the British teams this year, with the report of the head judge from the last year's British competition has highlighted a number of factors. Not only has there been an improvement in standards, but also what I perceive to be a dangerous trend in performance at the competition. This is, to perform to the competition requirements, rather than adopting a realistic approach to an incident. While this may not be very significant in the competition environment, it is still over to the operational scene, it has the potential to cause a serious distraction to the real purpose of the rescue crew. One such example was a reference to safety considerations by the 1991 head judge.

"...the cutting starts and leaving large amounts of work around to be done etc...
competitors dragged through mud to enter open wounds, etc..."

This appeared to have been taken in and needed by the British teams competing this year in some cases, to irrelevant lengths. Instead of attempting to develop or learn new techniques for best removal that will reduce the amount of splinter, several teams appeared to be quite happy to produce the same result, and then commit a team member to use a dust pan and brush to sweep up the glass. This was, however, not indicative of the performance of all British teams, with the winner of the world competition, judged by international judges, being a British team. To one team's credit, a vacuum cleaner was used.

The judges evaluation form for the competition is included at Annex B. Although more simple than the evaluation process used for Victorian RAR accreditation purposes, it allows reasonable comparison of the performance of teams in this competition with that of VICES units, during the skill demonstration phase of the Combined Emergency Services RAR assessment process. Doing so suggests, I believe, that the performance standard in Victorian is significantly higher than in Britain. At the other end of the scale, are those VICES units which set the standards for others to follow. It is of course, conjecturing to try and place them in the international competition and predict results, however, I believe it reasonable to suggest they would have scored in the top four.

A final day observation in the team's given to a workshop used to cut an opening into the rear side wall of a two storey car. This is so close to opening or blind over the 'B' pillar and the rear wheel arch. The process involved removal of the 'B' pillar.
Both the 1991 and 1992 head judge was Jim Taylor, who has 23 years experience in the fire and rescue service. He is head judge of the British section and is responsible for the standard and training of all British judges.
Comparison has been limited to VICES unit rescue units, as the author does not have sufficient first hand experience in the performance capabilities of other services to compare with VICES.

WORLD EXTRICATION '92

TRADE DISPLAY

World Extrication '92 incorporated a trade display with some 30 companies exhibiting their products. This not only generated interest in new and existing equipment in the market place, but also facilitated the exchange of ideas between all present.

Equipment on display, can be broadly classified into the headings discussed below:

Hydraulic Tools:

Products on display included both hand operated and powered hydraulic tools, from a range of manufacturers larger than that seen in Australia. The manufacturers included (in alphabetical order):

| | |
|----------|------------|
| Amkus | Lukas |
| Enerpac | Nike |
| Hi Force | Power Team |
| Holmatro | Weber |
| Hurst | Zumro |

In addition to this range, the western European market place also includes the French manufacturers Bemaex and Sides, as well as the Italian brand Gallego. There are also a number of eastern European, in particular Russian manufacturers. Despite this, the range of tools and associated accessories in the market place, does not widely vary from that available in Australia. Although product range and quality does vary significantly from one manufacturer to another, the major advantage to the European buyer, is a much greater choice and associated bargaining power.

To expand the standard kit of hydraulic tools carried by most rescue units, several manufacturers have already had success with the introduction of small hand operated, pedal or 'Toe' cutters. These are widely accepted as part of the standard kit of tools. Moves are now being made by Halmatro, Lukas and Nike, among others to expand this to include compact power packs. Lukas and Halmatro have also introduced hand operated combination tools. The compact power packs are small light weight (typically 20-25 kg) hydraulic pumps capable of powering one, or sometimes two tools. The major advantage of which is portability and space saving. The advent of such an innovation was principally brought about by the need to reduce size and weight for helicopter based rescue services. Following on from this has been the development of the 'all in one' tool consisting of either a spreader, cutter or combination tool, with an integrated hand pump, weighing in at between 10 and 12 kg, these tools are intended to have a 'first-aid' role.

At the other extremity of the scale, Lukas has made developments in specialist tools for re-railing of carriages and locomotives. Such items incorporate the hydraulically powered sliding platforms on which carriage bogies can be placed, in order to move them back onto the rails.

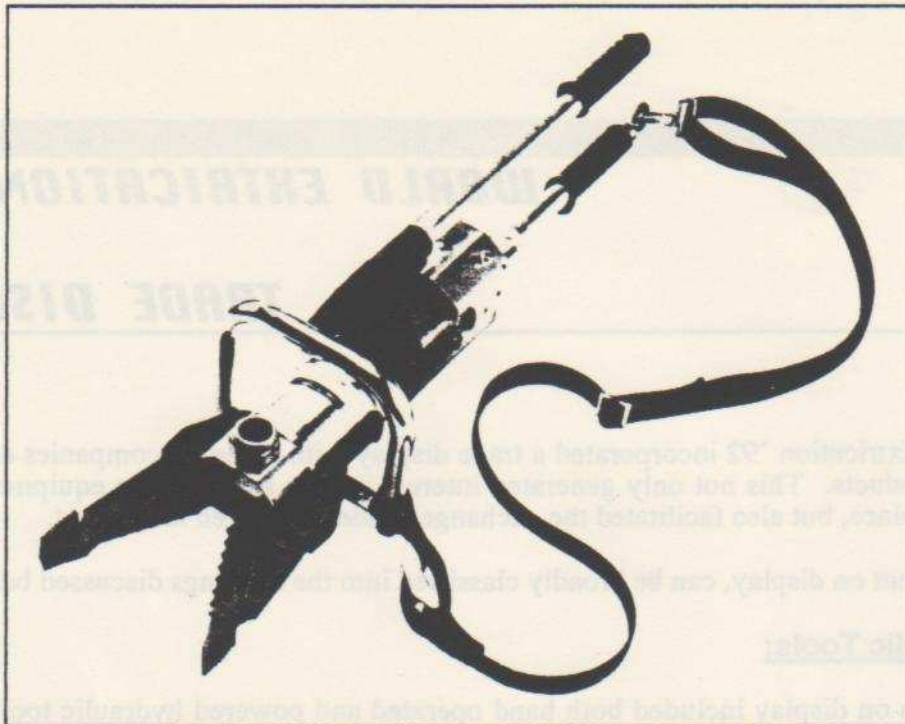

Figure 5.1: The Lukas Unitool combines a hand pump with a combination spreader and cutter to produce an all in one tool.

New innovations in the field of cutters by various manufacturers have also seen the recent introduction of serrated blades of various shape. These have varied from the traditional concave (non-serrated blade) through straight to convex. Perhaps the most recent new idea comes from Hurst, possibly as a result of their association with Godiva pumps and Hale. They have developed a water driven hydraulic pump. This unit operates in much the same way as air, electric or combustion units do, by forcing an impeller round to develop hydraulic pressure. The difference being, that water pressure is used. This pressure is provided from the pump on a fire tender and water is recirculated to the appliance.

Air Tools:

The range of products displayed included both air bags and air driven hand tools. With the exception of the introduction of kevlar construction air bags, few advances, specifically aimed at rescue, have been made in this field. The range of products includes both low and high pressure lifting bags, leak and pipe sealing bags, as well as aircraft lifting bags. The two major manufacturers in the European market place are Vetter/Vepro and Lampe, with several of the hydraulic tool manufacturers having a separate range of air bags to compliment their tools.

Hand Tools:

The range of hand tools was not extensive, with the well known range of Paratech tools creating much interest. Two new tools both in the field of glass cutters that generated significant interest were the US manufactured 'Glas-Master' and the Swedish 'Powercutter' by Nike.

The Glas-Master which costs about AUS\$200 is a hand tool, which the manufacturers claim will allow windscreen removal in under one minute. The tool consists of a short solid bar, with a saw blade at one end, and a hammer head which acts as a handle at the other. One end of the hammer has a spike to pierce the glass. This, then, allows access for the saw to cut the glass. Also included in the tools front handle, is a spring loaded centre punch for removing non laminated windows.

The Powercutter by Nike is hand held and weighs less than 2kg. It consists of a mini cutting wheel (approx. 3cm in diameter), with adjustable depth, designed for cutting laminated windows. The device is available in three configurations, with the top of the range costing about AUS\$480. The first of these is powered by an electric drill, while the other two are air driven. The difference between the air driven models being that one has a suction facility fitted to remove glass shards and swarf from the area.

A range of products from the patient care and transport, protective clothing, and warning device fields was displayed from many well known suppliers and manufacturers.

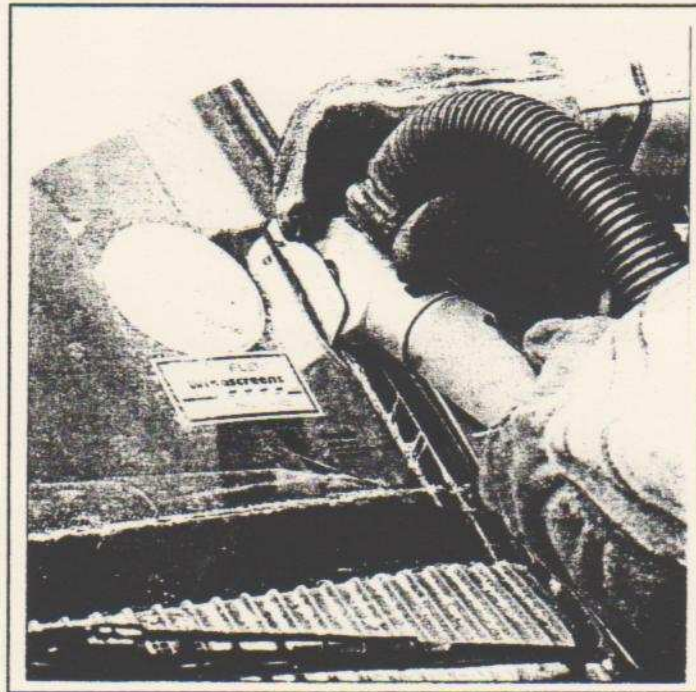

Figure 5.2: The Nike Powercutter has a built in diamond tipped cutting wheel and vacuum facility for removing glass shards and swarf.

Hazmat Control Products:

Two products from the German company Öko-Tec were demonstrated, both of which have potential applications in hazmat spill incidents, as well as a range of other incidents where a mobile levee bank is required.

The first is a double tubed barrier. This consists of polyethylene sheeting, up to 150m long, heat sealed into two (joined) tubes, one of 40cm diameter, and the other 20cm. The poly-sheeting is laid out to the desired length and cut off. Special sealing ends, with fill points are then attached. Depending on whether the spill is on land or water, the large tube is either filled with water, or air respectively. The small tube is always

water filled. The device can then be floated out onto water, or run around a land spill. If more than 150m is required, two sections can be overlapped to provide extra length.

In a land situation, any small leaks under the barrier can be plugged using the second product marketed by the company. That is Uni-safe, an oil and chemical binder. This product comes in a powder form, and is used to bind (soak up) fluid spills, of any pH. The product which may be used either independently or with the tube barrier, has no pH effect on either water or the chemicals it binds. That is, if used as a water dam, flora and fauna will be unaffected, while bound chemicals in a hazmat spill, will remain at the same pH, but will be in a solid state. Provided, the spill is completely covered, any toxic fumes will also be smothered.

A limited amount of extra information on all of the products described is available on request.



Figure 8.3: The Hexa Powdercutter has a built in diamond tipped cutting wheel and vacuum facility for removing glass shards and waste.

Hazmat Control Products:

Two products from the German company Olo-Tec were demonstrated, both of which have potential applications in hazmat spill incidents, as well as a range of other incidents where a mobile levee bank is required.

The first is a double tubed barrier. This consists of polyethylene sheeting up to 150m long, heat sealed into two (joined) tubes, one of 40cm diameter, and the other 20cm. The poly-sheeting is laid out to the desired length and cut off. Special sealing ends with fill points are then attached. Depending on whether the spill is on land or water, the large tube is either filled with water, or air, respectively. The small tube is always

TRAINING MATERIAL:**HEAVY VEHICLE
RESCUE TECHNIQUES****Introduction:**

The information presented here is a summary from a number of different sources. The majority, however, comes from the work of the CUEES organisation and my sincere thanks for their valuable assistance in this area. The content of this section is intended to highlight some of the problems in the field of heavy rescue, as well as offer some possible strategies to overcome them. This is in keeping with the CUEES philosophy of promoting information exchange and the sharing of ideas and knowledge between rescue personnel.

Accident Types:

Accidents involving trucks (rigid and articulated) and buses are not as common as those involving cars. In Britain, however, in 1990 over one third¹ of all fatal accidents involved heavy goods vehicles (HGV)². Of the 1799 HGV fatalities in 1990 in Britain, only 67 were occupants of heavy vehicles. Despite this relatively low number (3.4%), extrication of casualties from such entrapment presents significant problems.

Incidents requiring extrication, from the heavy vehicles can generally be classed in one of five categories:

1. **Side impact to cab**, which often results from an attempt to avoid some other form of collision. This type of accident can result in movement of body work and in particular the 'A' pillar into the compartment of the vehicle, entrapping the driver. Typical injuries can extend from head to toe, with fractures to femoral shafts, pelvis, chest and spine the most common.
2. **Vehicle roll over** is caused when vehicle speed (too high) and turning circle (too tight) combine to shift the centre of gravity outside the dimensions of the vehicle. Depending on the construction of the cabin (steel or fibre glass) and the type of roll over (side or fully onto roof), the level of extrication may be as simple as providing a ladder to allow the casualty to climb out through the upper most door.
3. **Front impact with a lighter motor vehicle**, often results in a 'Ride over the top' situation, in which the car tends to fold over and be crushed under the front of the truck, often entombing the car occupants. It has been noted in the United Kingdom, that in this sort of situation, cars are more likely to erupt into a ball of flame. Usually the

1 Figures supplied by British Department of Transport, show that 1799 fatalities of a total of 5217 resulted from accidents involving heavy vehicles.

2 In Britain a HGV is defined as any vehicle with a tare weight in excess of 1.5 ton and generally six or more tyres.

heavy vehicle occupants escape unhurt, sitting over the top of the accident. Injury patterns in this instance tend to relate to fractures of the tibia, fibula and ankles, resulting from foot entrapment due to pedal and lower metal panels of the heavy vehicle moving.

4. Front impact with another heavy vehicle. The most common presentation of this type of accident, is in collision with the rear of another similar vehicle. Typically this occurs on the open highways and freeways, on which heavy vehicles have a tendency to follow in close proximity to one another. This type of collision usually results in severe damage to the following vehicle's cab (especially if of a forward control design). The front of the cab will be pushed back into the cab shell, pedals, steering column, dash and windscreen are also displaced and cab doors are likely to be jammed. The floor of the cabin may also fold up depending on the speed of impact. Injuries, particularly for drivers, are likely to be severe, affecting all organ systems. Special consideration needs to be given to the likelihood of spinal injuries, as a result of such a shunt.

5. Movement of the load into the cab. This type of incident is fortunately rare, but can result in significant injuries to heavy vehicle cabin occupants. Injuries are typically in the form of either a crush or an impalement, with a common result being a compromised spine. The generally more severe impaling injuries have generated considerable debate about the best approach to extrication, possibly because of their relative low incidence. The generally accepted guidelines recommended are:

- (a) No attempt to be made remove the impaling object;
- (b) That medical care be facilitated as matter of urgency to provide a minimum of two intravenous lines for administration of analgesic and fluid replacement; and
- (c) When cutting the impaling object in order to extricate the casualty, vibration must be kept to a minimum. The British Fire Services recognise that this may necessitate the use of 'Hot cutting'³, and accept this technique provided appropriate precautions are taken.

It is also possible for a combination of these categories of accident type to occur, depending on the circumstances, with vehicles frequently coming to rest inaccessible areas off the road. This often necessitates some lateral thinking when working on soft ground etc.

Rescue crews will be faced with a range of problems, in excess of the normal, when attending a HGV incident, the most likely of which will be the height of the driver in the cab from the road. In all cases the initial approach should be similar:

Stabilise the scene

Stabilise the vehicle

Stabilise the casualty.

Throughout this process, the rescue team leader must remember that the philosophy of rescue is to 'Make space'. That is, create an opening wide enough to remove the casualty, and avoid trying to fit the casualty through the available space. In addition to the normal safety practices, consideration should be given in the 'Scene assessment and stabilisation phase' to the type of cargo being carried by the vehicle, which may mean a modification in the 'Plan of attack' for extrication.

³ Hot cutting is the use of an open flame, such as an oxy-acetylene torch, plasma cutter or thermal lance, to cut metal. This has traditionally been avoided if possible, because of the risk of fire at the scene of a motor vehicle accident.

Cabin Construction:

In the same way that a skilled rescuer must have a working knowledge of motor car construction/design, so too must he/she have a working understanding of the designs and elements used to build heavy transport vehicles. Heavy vehicle cabs can be made up with any of the following combinations:

- Either traditional long nose configuration or forward control;
- Either rigid (fixed to the chassis) or tilting cabs;
- Either all steel, fibre glass or a combination of both in construction; and
- Either with or without a sleeper built in on prime movers.

Older style rigid cabs tend to be an all steel construction, including the internal structures such as instrument panels. These vehicles have a normal 'A' and 'B' pillar construction and the doors can weigh between 50 and 100 kg, with substantial door hinges and lock mechanisms to support/secure them. Windscreen mounting varies, but is commonly of a key lock rubber type.

The more modern rigid cabs and tilt cabs may be either a steel or fibreglass construction, or more commonly a combination. Most of the internal structure in these vehicles is much like the average car, being plastic. The old style rigid driver's seat has been replaced by either a fully adjustable or air suspension seat, and the windscreen is more commonly laminated and bonded in place. The construction of the cabin is more solid than earlier designs, with an emphasis on a crush resistant sub frame (See Figure 6.1), with plastic or glass fibre panels bolted on. This type of vehicle often has fibreglass layers in the walls, for both thermal and acoustic insulation. The tilt mechanism can either be a simple mechanical counter balance, or a double acting hydraulic ram, which is used to raise and lower the cabin for mechanical work on the vehicles engine.

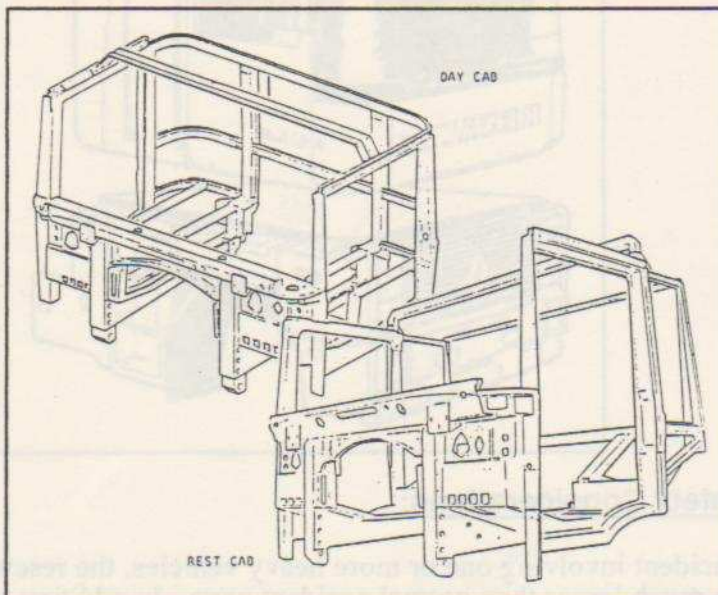

Figure 6.1: A modern forward control truck generally has a steel sub frame and is clad externally with fibreglass and internally with plastic. Glass fibre layers used to fill the walls to provide insulation.

Prime movers tend to be larger, and taller than the average rigid vehicle. Construction of the modern vehicles again tends to be a combination of steel sub frame and fibreglass panels, with on occasion a fibreglass sub-structure to support the panels. This offers even less protection to the occupants. Sleepers, when fitted, add an average of 0.5 metre to the length of the cabin. In Europe some are fitted above the cabin rather than behind, thus increasing the height by about 0.5 metre. Given the popular use of air scoops in Australia to improve fuel efficiency, this may be a viable consideration, if the aero-dynamic shape is maintained.

Renault in Europe have developed a new forward control prime mover (See Figure 6.2). The main difference to the rescuer is that the cab height is increased to 3.5 metres. The cab is fitted on top of the engine, as a separate structure, offering sufficient space to allow the driver to walk around. The driver's seat positioned slightly more rear of the front axle than its rigid counterparts, offering marginally more safety in a frontal impact.

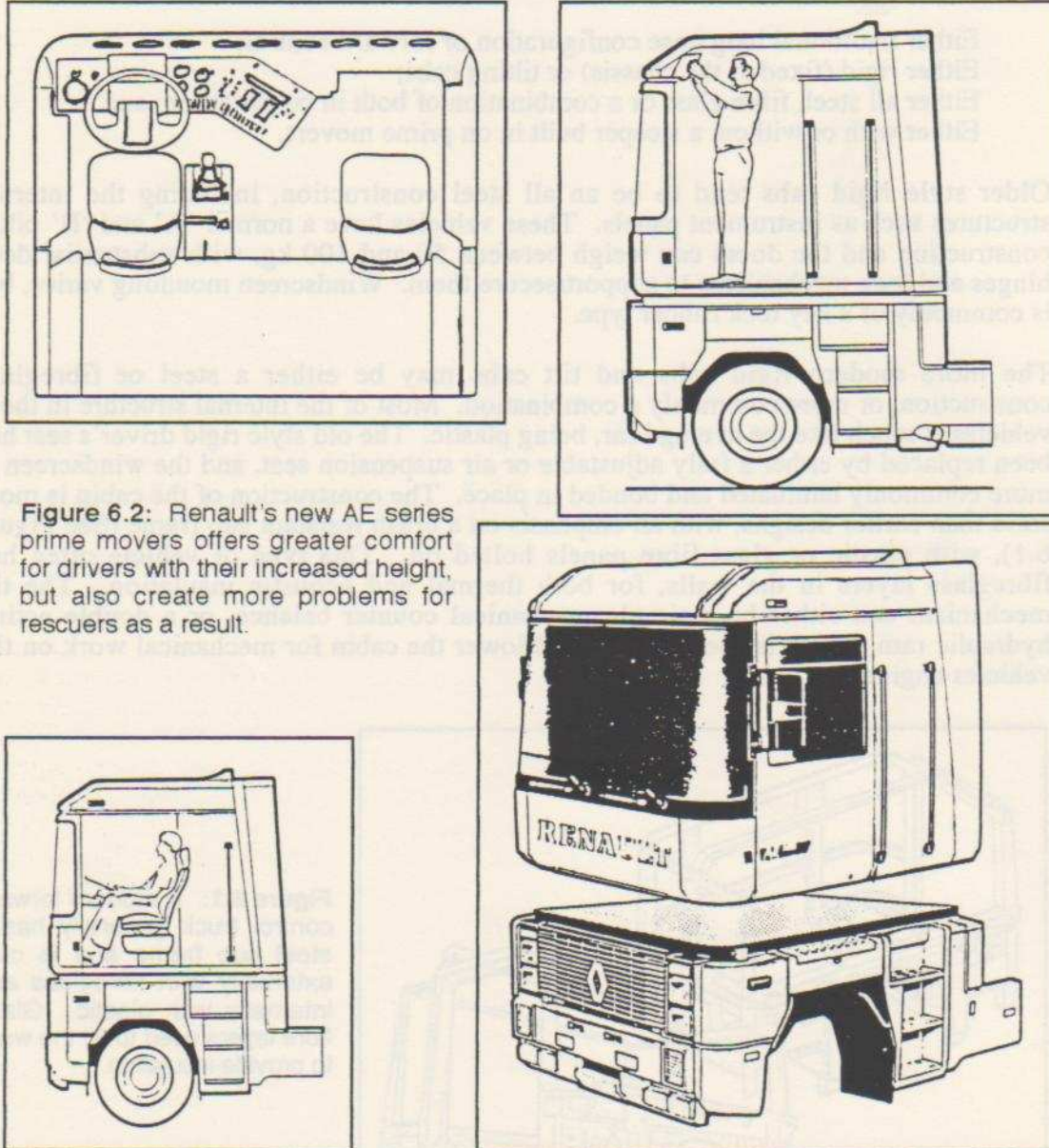

Figure 6.2: Renault's new AE series prime movers offers greater comfort for drivers with their increased height, but also create more problems for rescuers as a result.

Scene Assessment and Safety Considerations:

On arrival at the scene of an incident involving one or more heavy vehicles, the rescue team will be confronted with a much larger than normal accident zone. In addition to the normal considerations for scene assessment or size up, the team leader should consider the need for additional equipment to address the extra height of the vehicle. There may also be the need for heavy duty equipment if there is likely to be a larger lifting/cutting requirement than is capable with the equipment on hand.

Consideration should also be given to additional hazards which may exist. This goes beyond the obvious hazards related to the vehicle's cargo. British Fire Services have reported incidents of maxi brake chambers exploding in vehicle fire situations. This is

caused by the melting of the outer housing of the maxi brake, allowing the compressed springs to release their stored energy. Shrapnel is projected over large distances, as a result. This combined with the natural orientation of the maxi brake chambers on the axle (Angled a few degrees above the horizontal), has the ability to produce a missile like trajectory for the spring. Accordingly, extreme caution is recommended at the rear of vehicles fitted with maxi brakes, in a fire situation.

Vehicle stabilisation is also more involved than for a normal car. It must be remembered that the purpose of stabilisation is not only to make the vehicle safe, but also to reduce vehicle movement and vibration effects on the casualty. In the case of a heavy vehicle, this means, consideration must not only be given to movement of the wheels and vehicle suspension system, but also to the tilt cab. This will be necessary either, if its mechanism has been damaged as a result of the accident, or as is the case with a number of newer models, the tilt cab is mounted on gas struts, to give a smoother ride. Consideration may also have to be given to the air suspension seat on which the casualty may be sitting.

Securing of a vehicle fitted with air brakes should include the chocking of wheels from both directions. Application of the vehicle's park brake is not recommended, unless the air brake system is intact, and either sufficient air exists for the brakes to be released after application, or an alternative supply is available to recharge the system. The reason for the recommendation not to apply the park brake, is similar to current thinking on disconnection of battery terminals rather than cutting of cables. Not only may the battery need to be reconnected at a later date, but the vehicle may need to be moved in order to effect the rescue, which will be far more complex if the maxi brakes have locked on, with no air to release them.

Stabilisation of the vehicle's chassis can be assisted, in the case of an articulated vehicle, by the use of the trailer's landing gear. This will assist in stabilisation of the rear of the cab. Heavy duty blocks and jacks can also assist toward the front of the cab. Other methods include the jamming of wedges between spring leaves or travel buffers in air suspension systems. This, however, is not recommended because of the danger to rescuer associated with the placement of the blocks. Another method, subject to sufficient rams and blocks, is to place a hydraulic ram in each corner under the chassis and raise the cab to create a secure and stable working platform. This will, of course, require packing with blocks to secure the vehicle.

Pneumatic Seats:

Air suspension driver's seats also present more potential hazards and considerations for rescue personnel, than the conventional truck seat. While both the conventional and pneumatic seats are fully adjustable, for driver comfort, the air operated seat is automatic, relative to the manually adjustable mechanical seat. As all rescuers will know, one of the first considerations to free a trapped driver, should be to assess how much, if any, movement exists in the seat adjustment mechanism. This may prove sufficient to free the trapped driver, especially if the seat has the array of adjustments in height and squab angle that most mechanical truck seats have.

The pneumatically operated seats, however, are significantly different. They operate on a compressed air supply of between 90-150 psi (620-1030 kPa), which is supplied from the vehicles braking system. The seats vary in design, but most have a neutral position in the centre of their vertical travel range (See Figure 6.3). When the driver sits on the seat, it sinks under his/her weight. This causes an inflation valve to be mechanically operated, filling an air bag under the seat squab, causing it rise until the neutral position is reached, at which point the valve turns the air supply off. This provides the driver with a comfortable ride. When the drivers leaves the seat, it rises as a result of the pressure in the air bag. This causes a second (exhaust) valve to operate, releasing air until the seat once again returns to the neutral position. The total vertical travel of the

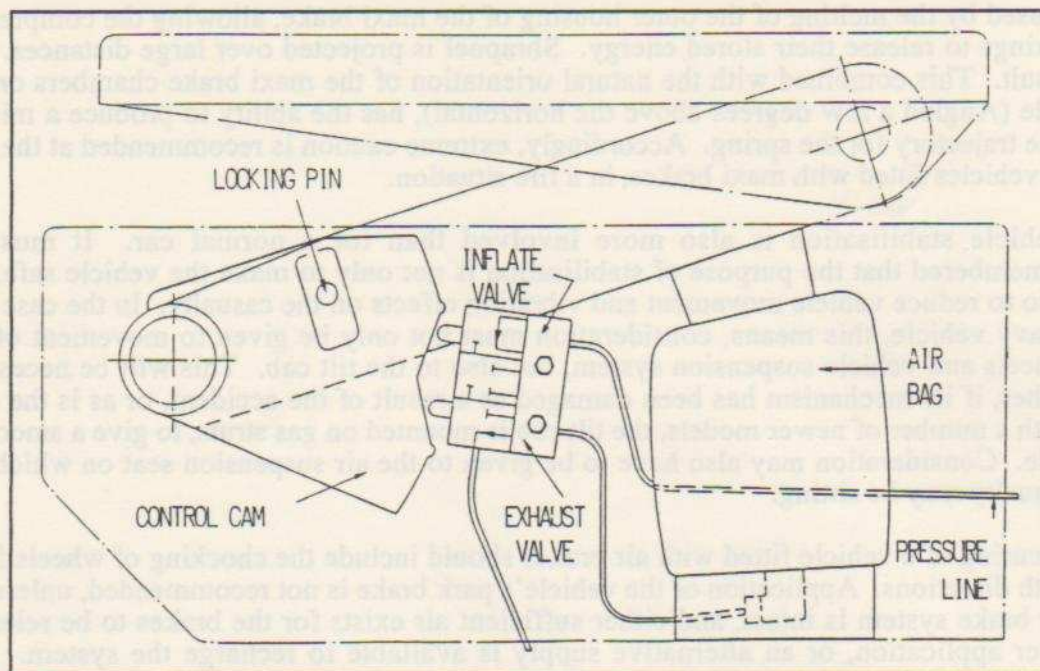

Figure 6.3: Cam operated air suspension seat. As the driver sits, the upper valve operates, causing the air bag to inflate. When driver leaves the seat, it rises, causing the lower (exhaust) valve to open.

seat varies from one manufacturer to the next, but averages about 8-10 cm. The valves can be manually operated, either to inflate or deflate, and the seat can be locked in the neutral position. This is achieved by a control usually mounted on the front of the seat between the driver's legs. Some seats also have air bags in the seat back to provide lumbar support, these are inflated by way of rocker switches on the side of the seat (See Figure 6.4).

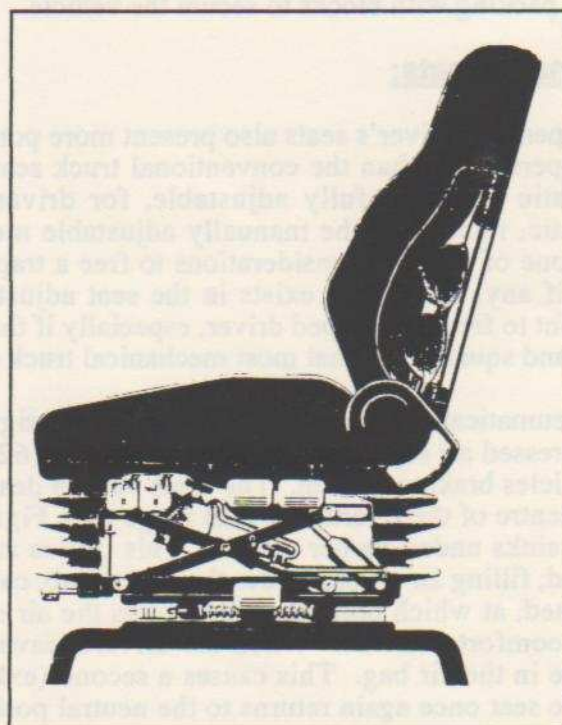

Figure 6.4: Air suspension seat showing lumbar support air bags.

This type of seat presents problems for rescue personnel. In an incident in which the dash board and steering wheel are pushed down on the driver, the seat will also be pushed down. This will cause the inflation valve to operate and the seat will try to counteract the downward action of the dash, etc.. The effect of this will be to further confine the driver, and aggravate any injuries. When an extrication is attempted, the seat will commence to rise until it reaches the neutral centre position, which may be significantly higher than is necessary to extricate the casualty.

The recommended procedure to address this situation is as follows:

1. If possible ascertain if an isolation valve exists for the seat mechanism. This may be located either under or near the seat, or on the outlet hose from the vehicle's air system reservoir which leads to the seat. If this can be identified and operated, it will save having to drain the whole air system of the vehicle. If so proceed to step 4.
2. If the valve cannot be found, or is not fitted, choke all wheels, from both sides, to prevent the vehicle moving.
3. Locate the drain valve on the vehicle's compressed air reservoir and drain the whole system. Avoid cutting any air lines if at all possible, as these may be under pressure and will also be required to move the vehicle at a later date.
4. Place blocks and wedges under the seat to maintain its position.
5. Puncture the air bag to release the pressure. Eye protection must be worn to ensure dust and debris does not cause injury.
6. Check the seat is secure and carry out extrication as normal.

Notes:

- (a) It is not recommended that the air bag be punctured without chocking the seat, as this may cause uncontrollable movement of the seat, and further injury to the casualty.
- (b) Selective deflation of the lumbar support air bags, where fitted may also assist to provide extra space for extrication.

Rescue Techniques:

The details provided below are intended to be suggestions only, and reflect the techniques being promoted in Britain. They will hopefully stimulate discussions and idea exchange. Local policy and procedures must always be given precedence.

Three basic techniques are described. Each one is broad based and may need modification, depending on the particular circumstances of an incident. The techniques essentially relate to forward control or cab over vehicles, as these present a greater challenge to the rescuer, than the traditional long nose trucks, which can generally be approached in a similar manner to a motor car. In all cases, the scenario considers that the vehicle is on its wheels. Obviously, modification of the basic idea will be necessary to cater for variations to this.

The whole process involves ramming, fixed winching and strategic cutting or crushing.

The aim is to open the doors and conduct fixed winching/ramming with strategic crushing and cutting to expose the interior of the cab. This will allow optimum space to be gained in order to extricate the casualty.

Technique One:

Opening of doors will often be difficult due to the height of the cabin. It may therefore not be practical to attempt to open them by spreading, unless the accident damage lends itself to this. A much easier tool to use above the head is the air chisel. Care must be

taken to protect the casualty, both from the physical action and the noise of the tool. Using the air chisel, the outer skin of the door can be removed, exposing the lock mechanism. If this does not allow the door to be opened, the whole door may need to be cut, leaving just the lock attached to the B pillar. In this case, in particular, casualty care is paramount, use of a short backboard, will assist in this task.

The next task is to determine a course of action for the roof. If it is to be removed, this is generally more involved than for a car, because the pillars aft of the 'A' on a truck tend to be much larger. It may also be necessary to work from ladders. If possible, the roof should be left attached at one end which avoids the problem of having to lift a large and heavy roof clear of the casualty.

If the roof is to be removed, then all windows should, if possible, be removed from the vehicle first. The rear pillars and roof supports can now be cut at the base of the windows, using an air chisel or reciprocating saw. Strategic crushing of structural ribbing may be necessary to facilitate this. Next the A pillars are part cut. This will prove useful on vehicles with a bonded windscreen. The roof can be flapped forward, and then if necessary, the A pillar cuts completed and the roof removed (See Figure 6.5). It is advisable to use guidelines on the roof during the flapping process, especially in high wind situations, because of its size and weight. If the roof remains attached to the vehicle it should be tied securely using the guidelines to reduce movement.

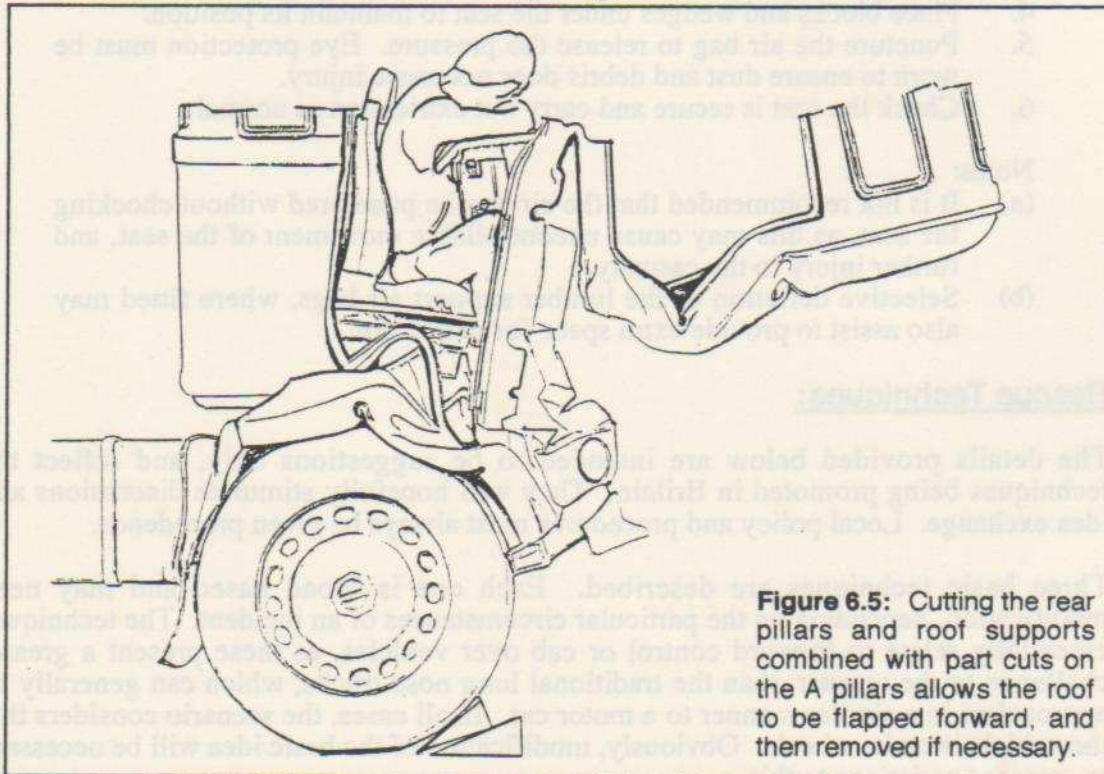

Figure 6.5: Cutting the rear pillars and roof supports combined with part cuts on the A pillars allows the roof to be flapped forward, and then removed if necessary.

Technique Two:

Another option involves leaving the roof attached to the main cab structure, by making cuts at the tops of the A pillars, after removing the windscreen. When making such cuts watch for welds near the top of the A pillar. On some heavy vehicles, the roof and upper A pillar structure is slotted into the lower part of the A pillar and then welded. The effect of this is to double the amount of metal in the A pillar which must be cut. Once the cut has been made a sling or strop can be placed around the steering column and the drivers side A pillar, and attached to a winch in front of the vehicle. The winch, either powered or hand operated, should be attached to a fixed anchor point in the form of a rescue vehicle, a constructed anchor, a suitable tree or post. Once the casualty is

suitably protected, the dash and steering wheel can be carefully winched forward. To assist this, the base of the A pillar can either be cut or crushed to weaken the hinge point (See Figure 6.6). Before and throughout the winching operation, attention must be paid to the tilt mechanism of the cab, to ensure it remains secure.

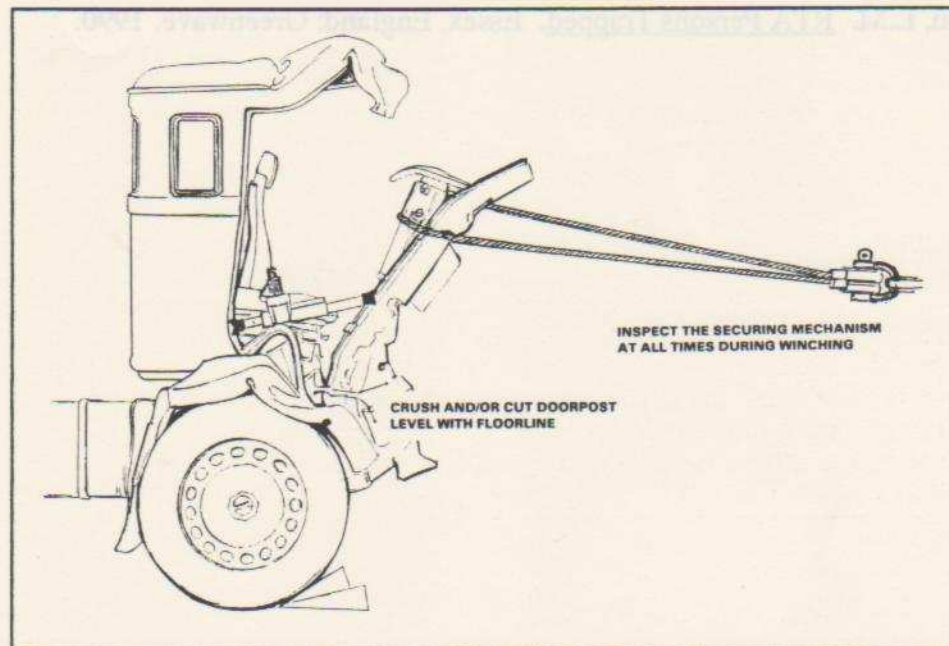

Figure 6.6: If the roof is left intact, and the A pillars are cut, the front of the vehicle can either be winched or rammed forward to release a casualty.

Technique Three:

If winching is not appropriate, similar results can be achieved by the use of either one or two sets of rams. Having made the cuts at the tops of the A pillars, and cuts or crushes at bases, rams can be used to push the dash out. The normal process for this is much like on a car, from base of B to top door hinge on the A pillar. Because of the size of most heavy vehicles a set of different sized rams will be required, so that a longer one can be slotted in to take over when the shorter one runs out of length. Ideally, this combination approach should be employed on both sides of the vehicle at the same time, if sufficient equipment is available.

Summary:

The information presented has not only covered a large range of topics but revealed a significant amount of detail in relation to extrication of trapped casualties in heavy vehicles. Clearly the keen and dedicated rescuer must have as extensive a knowledge of heavy vehicle construction as he/she does for cars, if not more. While the topics presented were perhaps not dealt with exhaustively, they, nonetheless, have provided a starting point in each case for further consideration and development of training, techniques and information.

The material provided by CUEES has identified additional hazards for the rescuer to consider on arrival at the scene of a heavy vehicle accident, as well as making an attempt to address possible solutions. In particular the stabilisation of the vehicle and the casualty, as well as possible options for extrication.

References:

Akers, M. A. Rescue for Heavy Goods Vehicles. Surrey, England: CUEES, 1992.

Watson, L.M. RTA Persons Trapped. Essex, England: Greenwave, 1990.

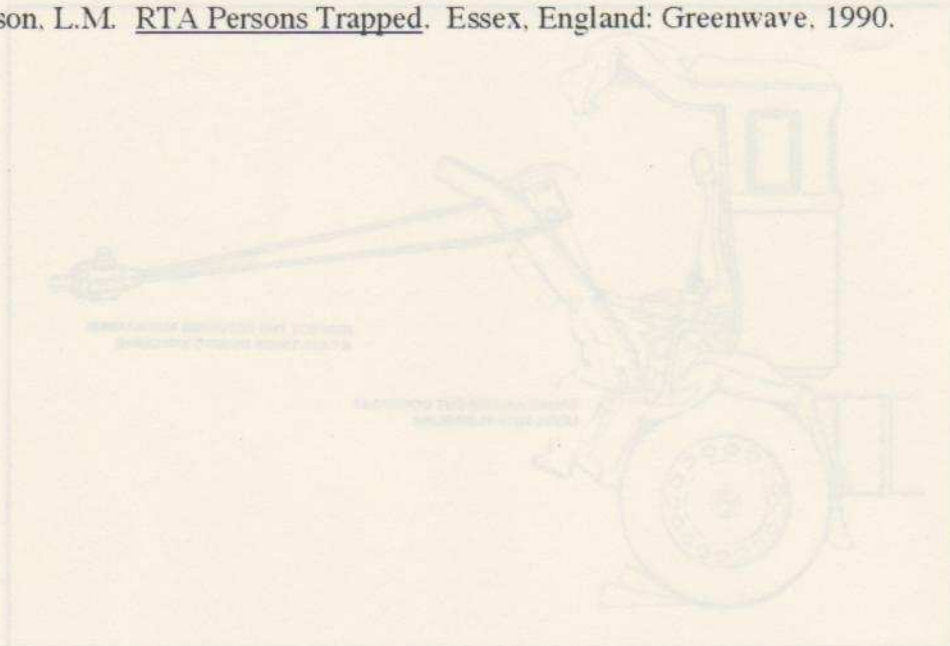

Figure 6.6: If the tool is inserted, and the A pillar is cut, the front of the vehicle can either be winched or released forward to release a casualty.

Technical Notes

If winching is not appropriate, similar results can be achieved by the use of either one or two sets of jacks. Having made the cuts at the top of the A pillar, and cuts on either side of the base, jacks can be used to push the dash out. The normal process for this is to attach the jacks to the top door hinge on the A pillar. Because of the size of most heavy vehicles a set of different sized jacks will be required, so that a longer one can be stored in to take over when the shorter one runs out of height. Ideally, this combination approach should be employed on both sides of the vehicle at the same time if sufficient equipment is available.

Summary

The information presented has not only covered a large range of topics but revealed a significant amount of detail in relation to extrication of trapped casualties in heavy vehicles. Clearly the team and dedicated rescue must have an extensive knowledge of heavy vehicle construction as well as the ability to cut. While the topics presented were perhaps not dealt with exhaustively, they, nonetheless, have provided a starting point in each case for further consideration and development of training techniques and information.

The material provided by CUEES has identified additional hazards for the rescuer to consider on arrival at the scene of a heavy vehicle accident, as well as making an attempt to address possible solutions. In particular the stabilisation of the vehicle and the casualty, as well as possible options for extrication.

TRAINING MATERIAL:

SUPPLEMENTARY RESTRAINT SYSTEMS

Introduction:

The information presented here is a summary of material accumulated from a number of sources, both Australian and international. It is intended to offer an introduction to the field, highlighting some of the dangers to rescuers and strategies to overcome them. My thanks to the CUEES organisation for the valuable information provided through their training literature and the workshops facilitated by them during World Extrication '92.

History and Development:

In 1970 Victoria lead the world with legislation requiring not only the installation of, but also the mandatory wearing of seat belts in motor cars. While this no doubt had a significant effect on the reduction of both severe injury and loss of life from motor vehicle accidents, little has been done since then, in Australia, to improve occupant safety, by way of legislation or improvement in design rules¹.

In 1967 an American automotive engineer named Lee Iacocca began a fight to have steering wheel air bags introduced into passenger vehicles in the United States. Today we still have just our seat belts, while Mr Iacocca has fitted his one millionth air bag and some five million are currently on US roads. By 1996, this figure is expected to rise to 60 million. From October 1989, all vehicles manufactured in the USA were required to have air bags fitted to protect at least the driver, and by 1994, all vehicles will require the same on the passenger side. Air bags have been responsible for a 30% reduction in deaths and 28% reduction in serious injury in the US and Europe².

Air bags are a passive restraint device for occupants of cars, particularly the driver. That is, unlike the seat belt, they do not require the driver to set/arm the bag to provide protection. They are designed to trigger in frontal and near frontal impact situations (See Figure 7.1).

Other design changes to safety are being made in the field of seat construction and shape, as well as the introduction of seat belt pre-tensioners and anchorage improvements. Electric latching doors are also becoming common place in both European and Japanese manufactured vehicles.

1 Australian Design Rules (ADR's) are currently in draft form to address this issue.
2 Figures from the US Insurance Institute for Highway Safety and the Highway Loss Data Institute

Based on the figures quoted, all of these devices are becoming increasingly prevalent on the road. The chances, therefore, of a rescuer encountering one is increasing dramatically. As well as improving safety for the vehicle occupants, these devices present a range of problems and dangers to the rescuer, when an accident occurs. This is particularly so, should the safety feature fail to operate. This may happen in the case of a side impact or roll over accident.

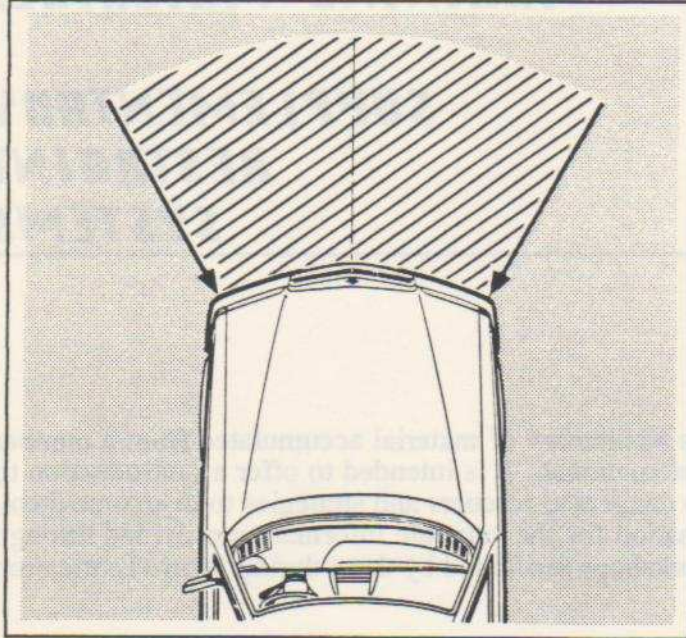

Figure 7.1: Crash sensors will only activate the Supplementary Restraint System as a result of frontal or near frontal impacts.

Air Bag System Components:

The air bag system is designed to supplement the use of seat belts, not to replace them. The system consists of crash sensors, one or two air bag modules (depending on whether a passenger side bag is fitted), back up power supply, an electronic diagnostic module and a wiring loom. The air bag is designed only to inflate following a frontal or

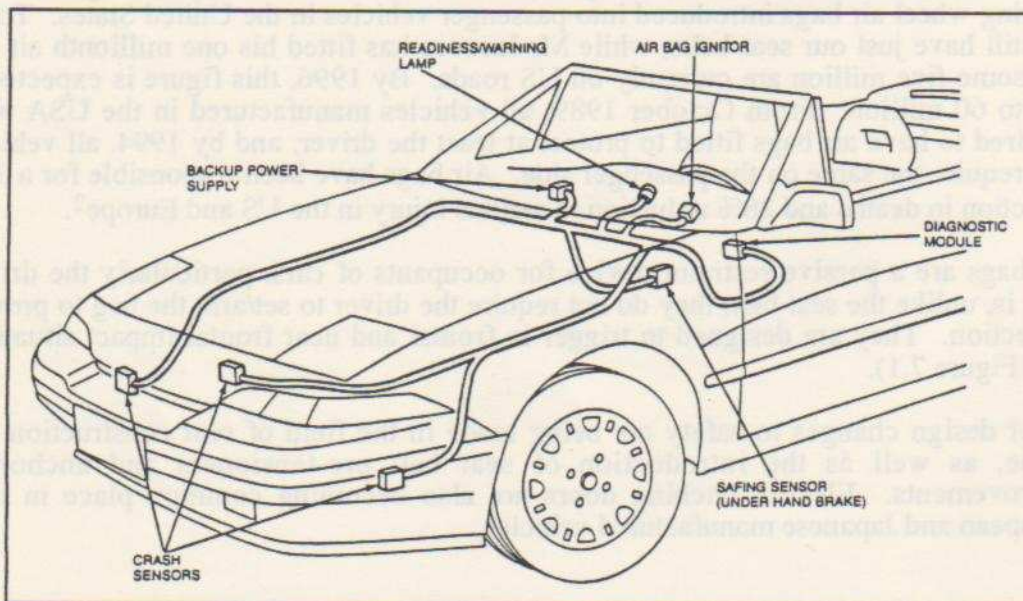

Figure 7.2: Ford impact sensors are divided into two groups. One sensor from each group must close together for the SRS to activate. (The centre mounted 'crash' sensor has both a crash and safing sensor mounted in it.)

near frontal impact, at speeds in excess of 20 km/h (ie. equivalent to a fall from a height of 1.6m), which are detected by the crash sensors. In the case of Ford vehicles, two out of five sensors must close simultaneously for the air bag to deploy. The sensors are divided into two groups (Crash and Safing sensors) mounted in various locations. One sensor from each group must close to cause an inflation (See Figures 7.2 & 7.3). The purpose of this dual switching system is to ensure the impact is severe enough to warrant triggering of the bag. It is also intended to avoid false triggering due to a sensor failure or short circuit.

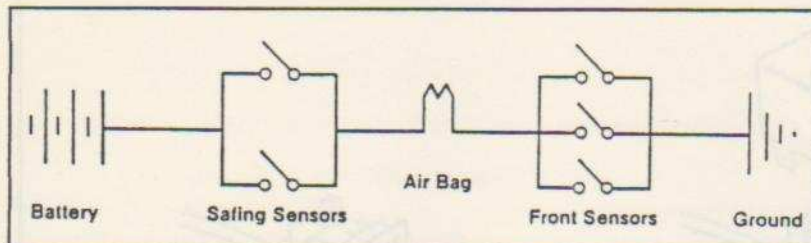
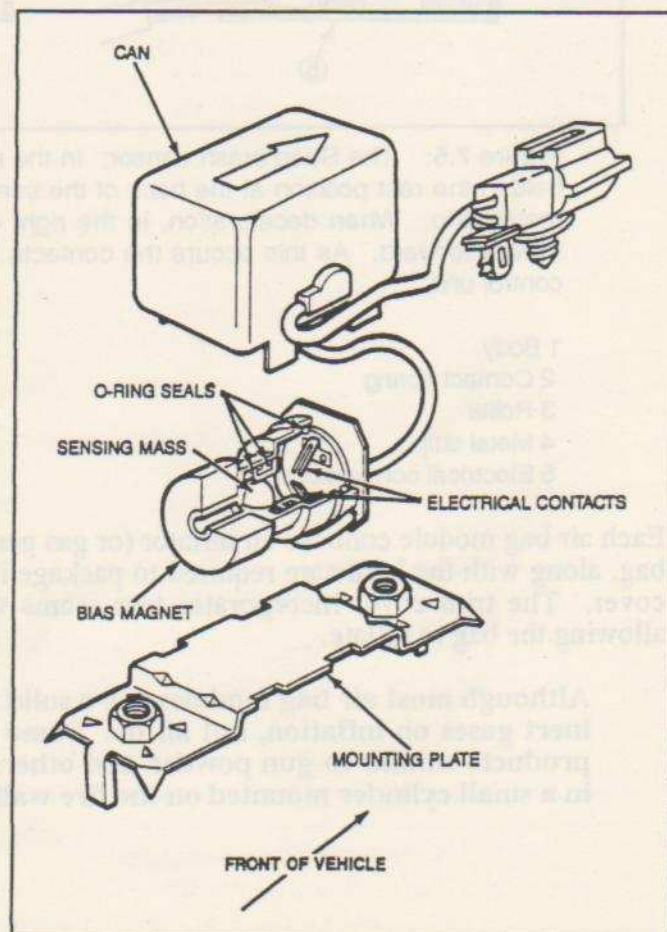

Figure 7.3: At least one Safing sensor and one Crash sensor must close simultaneously for the air bag to inflate.

The Ford sensor consists of a gold plated steel ball. The ball is held away from electrical contacts by a magnet at the opposite end of a tube. During an impact, if the change in the vehicle's velocity is great enough, the ball will break away from the magnetic attraction and travel down the tube and close the contacts. The travel of the ball is air damped by having a very small gap between the ball and the tube. This prevents closure of the contacts during short duration velocity changes. The major difference between a crash sensor and a safing sensor is the "ball to contact" distance which is reduced in the safing sensor (See Figure 7.4). This whole process from detection, through confirmation and ignition to commencement of deployment, takes about 20 milliseconds.

Figure 7.4: Electrically operated Ford crash sensors consist of a gold plated sensing mass (steel ball) held away from contacts by a magnet. The arrow on the can shows the front of the vehicle. When the vehicle decelerates rapidly the ball breaks away from the magnet and closes the contacts.



In the case of Saab vehicles the sensor operation principle is similar, however, a steel roller is used in place of a gold plated ball (See Figure 7.5). The roller (3) is held by a metal strip (4) which acts as a contact surface and a spring which is wound around the roller like a chameleon's tongue. If the sensor is subjected to a forward deceleration of 16g, the inertia of the roller exceeds the spring force of the metal strip. The roller moves forwards unwinding the metal strip causing the contact surface to touch the contact (2) in the base.

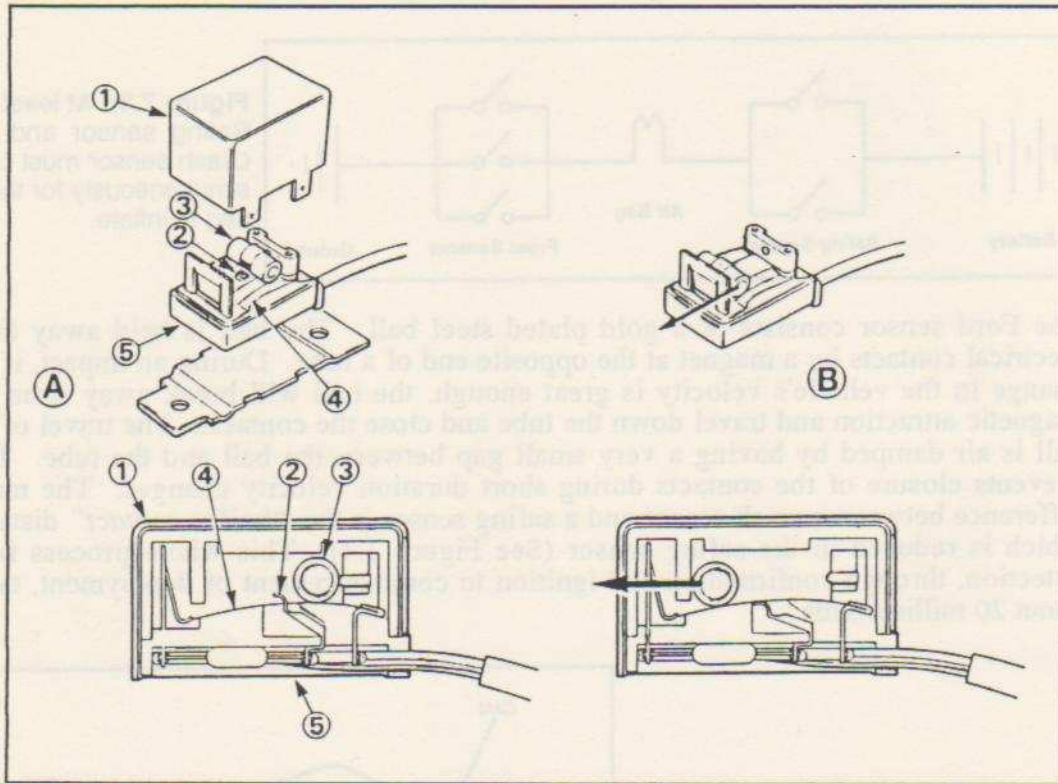

Figure 7.5: The Saab crash sensor: In the normal position (A) the roller is held in the rest position at the back of the sensor by the spring action of the metal strip. When deceleration, in the right direction, occurs (B) the roller moves forward. As this occurs the contacts touch, sending a signal to the control unit.

- 1 Body
- 2 Contact spring
- 3 Roller
- 4 Metal strip
- 5 Electrical connections

Each air bag module contains an inflator (or gas generator), an igniter and the folded air bag, along with the hardware required to package it behind the special soft plastic trim cover. The trim cover incorporates tear seams which separate during deployment, allowing the bag to inflate.

Although most air bag modules use a solid fuel which burns to produce inert gases on inflation, not all do. Some systems utilise sulfur based products similar to gun powder and others use compressed gas stored in a small cylinder mounted on the fire wall.

The sulfur based systems tend to use a mechanical rather than electrical igniter system, and are typically found in Jaguar and Toyota manufactured vehicles. This system which incorporates both the crash sensor and air bag in the one module operates in much the same way as the primer on a shot gun cartridge (See Figure 7.6).

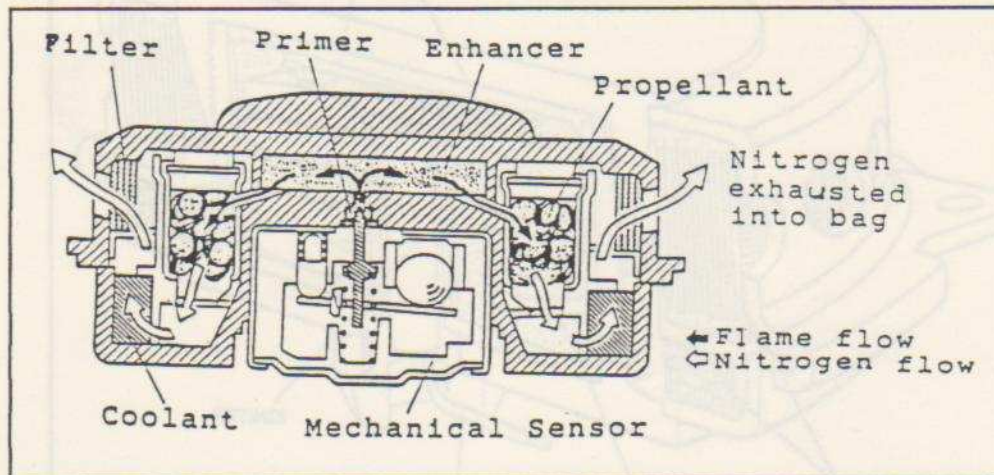

Figure 7.6: Mechanically activated air bag modules incorporate the sensor in the module. This device operates in a similar manner to ammunition, requiring a strike to activate.

The advantage of a stored gas system, is its non-explosive nature and the release of an inert gas (Argon). A solid propellant system, however, is not pressurised and gas evolution occurs at a pre-determined rate (based on the quantity of fuel). Conversely, the stored gas system has the disadvantage of requiring a bulky pressurised container (100 bar), from which gas evolution rates are temperature dependant, and therefore difficult to control. The disadvantage of a solid propellant system, is its explosive nature and the need to filter particles out of the gas before allowing it to inflate a bag.

In the electrically triggered air bag modules, the inflator contains a solid fuel which burns in an enclosed chamber to produce nitrogen (N_2) gas which is cooled and filtered prior to inflating the air bag (See Figure 7.7). The driver and passenger air bags themselves are very different. The steering wheel air bag is constructed of nylon fabric coated with neoprene and fills to a volume of between 40 and 80 litres (Depending on the size of the vehicle and whether the bag is intended to cushion only the head or the head and shoulders). The passenger side air bag is considerably larger for obvious reasons, having a volume between 180 and 250 litres. To keep weight down, the bag is constructed of light weight 'rip-stop' nylon (See Figure 7.8).

The electrically operated system includes a diagnostic module to self test the system and identify any faults. A back up power supply is also included in the system, should the battery of the vehicle become disconnected in the initial phase of the impact.

Operation of Air Bag Systems:

When the crash sensors detect a deceleration of sufficient magnitude, a signal is sent (either electrically or mechanically) to the igniter, which consists of a heater made from zirconium potassium perchlorate ($Zr-KClO_4$). This causes the 100-150 grams³ of solid chemical propellant sealed inside the inflator, principally Sodium Azide (NaN_3), to undergo a rapid chemical reaction. This reaction produces primarily Nitrogen gas which inflates the air bag. The only other bi-product which is not captured in the filter,

³ The quantity of chemical varies depending on the size of the air bag. In the case of passenger side systems, as much as 450 grams may be used.

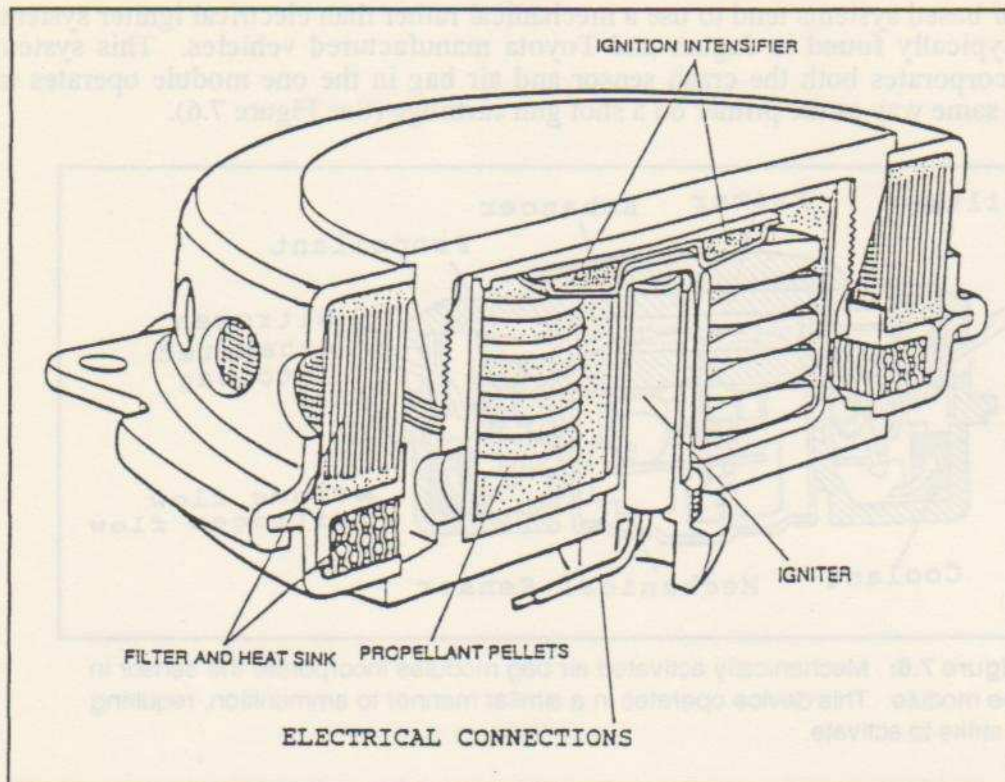

Figure 7.7: The sealed container of a steering wheel air bag module incorporates the solid fuel, igniter and a heat sink and gas filter.

housed inside the module, is a small amount of sodium hydroxide (NaOH). This is almost immediately converted to baking soda (Na_2CO_3). As the gas inflates the air bag, which takes about 15 milliseconds, it also begins to vent through holes in the rear (toward the front of the vehicle) of the bag. The whole process taking approximately 100 milliseconds to complete (The same time as it takes a human eye to blink). Another bi-product of the inflation process is the sound. The explosion generates a sound measured at 160dB.

Following deployment of an air bag, some smoke will be present in the vicinity. This will be a mixture of small traces of baking soda combined with corn starch or talc which is used to lubricate the bag during deployment. There are no accessible parts of the system which will be hot.

The air bag module is also designed to trigger if it reaches a temperature of 300°F (150°C). This is likely to occur in a vehicle fire situation. The purpose of this design consideration, is to ensure that the propellant does not become unstable and fragment or explode at a high temperatures.

Identification of Vehicles:

At present there are neither universally accepted markings nor requirements to display any such indicator that an air bag is fitted to a car. Some vehicles have SRS (supplementary restraint system) or SIR (supplementary inflatable restraint) or AIRBAG written on either the steering wheel boss or passenger side dash. The only other tell tale sign, on a vehicle in which the bag has not deployed, may be the enlarged/rectangular steering wheel hub.

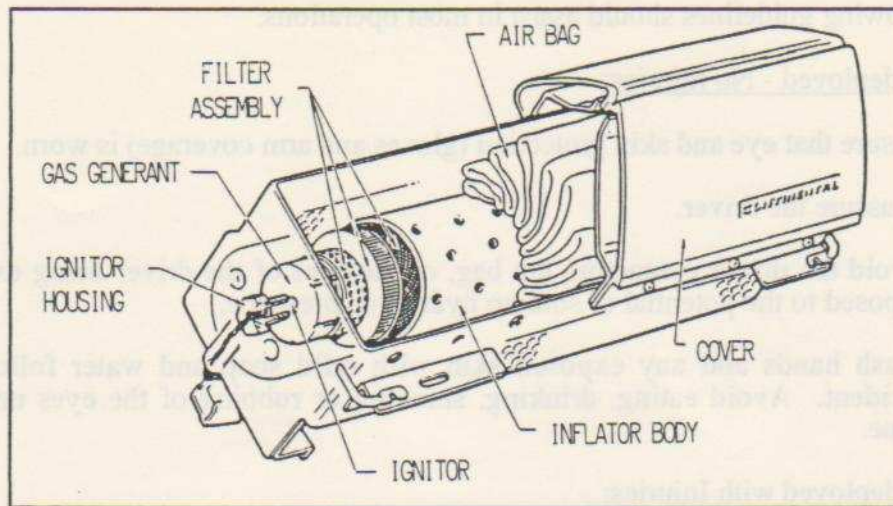

Figure 7.8: Passenger side modules are significantly larger with more solid propellant being used and a bag which expands to cover the whole dash area.

Most manufacturers also include a coding within their vehicle identification number (VIN) indicating the presence of an air bag system. However, once again, there is no common standard in the codes used, or even locations of VIN plates.

Rescue Considerations:

In view of the lack of standard markings, warning of the presence of air bag or other restraints in a vehicle, it should be assumed that all vehicles are fitted with an air bag until otherwise proven.

Emergency service personnel will encounter air bags in an accident vehicle in one of four possible combinations of scenarios. The air bag may or may not have deployed following the accident, and the occupants may or may not be injured/need rescue as a result of the accident.

In the two cases which include deployment, small traces of sodium hydroxide may cause skin and eye irritation. Therefore, all efforts should be made to avoid entry of the powder to casualty wounds and skin and eye protection should be worn by emergency service personnel.

To make the system safe the battery should be disconnected. Rescuers should be aware that the back up capacitor in the air bag system may still be capable of triggering for some period of time. This period of time varies significantly (1 second to 30 minutes) from one manufacturer to the next. In view of this, rescuers should work from the side of the steering wheel as much as possible, and avoid the deployment path.

NB. Disconnection is only possible for electrically triggered systems. Mechanically triggered systems cannot be deactivated in the field.

The following guidelines should assist in most operations:

Air bag deployed - No injuries:

- * Ensure that eye and skin protection (gloves and arm coverage) is worn.
- * Reassure the driver.
- * Avoid the driver contacting the bag, or the eyes of the driver being excessively exposed to the potential of sodium hydroxide presence.
- * Wash hands and any exposed skin with mild soap and water following the incident. Avoid eating, drinking, smoking or rubbing of the eyes until this is done.

Air bag deployed with Injuries:

- * Proceed with any rescue/treatment necessary immediately.
- * Ensure that eye and skin protection (gloves and arm coverage) is worn.
- * Avoid residue entering casualty's eyes or wounds.

Air bag not deployed with Injuries:

- * Proceed with any rescue/treatment necessary immediately.
- * Ensure a second team member disconnects the battery.
- * Avoid the deployment path of the air bag until the back up power supply has discharged. That is: work from the side of the steering wheel.
- * Place nothing against the module.

Air bag not deployed with trapped casualty:

- * Use battery if necessary to move electric windows or seats, or open any electrically latched doors.
- * Disconnect battery.
- * Avoid the deployment path of the air bag until the back up power supply has discharged. That is: work from the side of the steering wheel.
- * Use whatever rescue tools are necessary, and do not delay extrication procedures.
- * Do not cut or drill into air bag module.
- * Steering column displacement may be conducted once the system has been fully deactivated. In the case of mechanically triggered systems, extreme care should be taken to avoid sharp jolting impacts to the steering column, particularly in a forward or rearward direction. If this is avoided, cutting of the steering wheel rim is permissible.

The other form in which air bags may be encountered is during transport to a vehicle manufacturing site. Under these conditions the devices are transported as dangerous goods being classified as UN Class 1.4 Minor explosives.

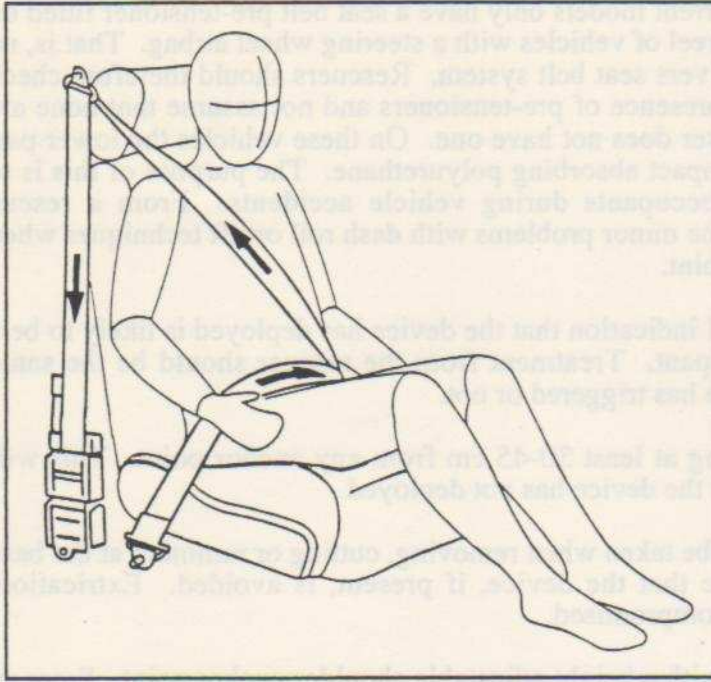

Figure 7.9: Inertia reel mounted seat belt pre-tensioner. On impact this device pull the belt down to tighten it. Similar devices can be mounted on the buckle anchor to draw it down at impact.

Seat Belt Pre-tensioner Components and Operation:

With the innovation of air bag restraint systems, has come the development of advances in seat belt protection. Seat belt pre-tensioners are devices which operate in support of the air bag systems to further restrain the occupant during rapid deceleration, thereby reducing serious head and chest injury (See Figure 7.9).

This device can be fitted directly to either or both of the lower anchor points (ie. reel or buckle) of the three point belt system. The device is triggered by similar (generally shared) sensors to the air bag systems, and once again only triggers on frontal or near frontal impacts. Like air bag units these devices can also be either mechanically or electrically triggered. When the device receives a signal from a sensor, the igniter lights and causes a gas to be generated in a small piston/cylinder system. This process is similar to the air bag system and uses the same chemicals. In the case of inertia reel mounted pre-tensioners, as the piston moves into the cylinder, a set of jaw clamps through which the belt passes before leaving the inertia reel housing, are rotated. This causes the belt to be wound in (See Figure 7.10). When the retraction of the seat belt is complete, the tension causes the anti-reverse gears to mesh with each other and the position of the belt is maintained. This process takes approximately 21 milliseconds to complete. In the case of buckle mounted pre-tensioners, the system is similar, but in this case the buckle is physically retracted as the piston moves, pulling the belt with it.

Identification and Rescue Considerations:

As with air bag systems, no standard or required markings currently exist to identify vehicles with pre-tensioners fitted. Given that seat belt pre-tensioners are generally found in the presence of an air bag, the rescuer should first establish this fact. Following this, the only tell tales that a tensioner is likely to be installed, will be either an enlarged inertia reel housing, at the base of the B pillar, or possibly an enlarged seat belt buckle anchor housing. As with air bags, in the first instance, assume the device exists until proven otherwise.

In the case of Saab vehicles, current models only have a seat belt pre-tensioner fitted on the front passenger seat inertia reel of vehicles with a steering wheel airbag. That is, no pre-tensioner is fitted to the drivers seat belt system. Rescuers should therefore check both seat belt systems for the presence of pre-tensioners and not assume that none are present simply because the driver does not have one. On these vehicles the lower part of the dash board is made of impact absorbing polyurethane. The purpose of this is to provide knee protection for occupants during vehicle accidents. From a rescue perspective, this may create some minor problems with dash roll or lift techniques when searching for a secure anchor point.

If one is present, the only visual indication that the device has deployed is likely to be a tightened belt around the occupant. Treatment from the rescuer should be the same regardless of whether the device has triggered or not.

- * Release the belt by cutting at least 30-45 cm from any anchor point. This will allow the belt to retract, if the device has not deployed.
- * Considerable care should be taken when removing, cutting or ramming at the base of the B pillar, to ensure that the device, if present, is avoided. Extrication, should, however, not be compromised.
- * Some vehicles are fitted with a height adjustable shoulder anchor point. From an extrication point of view, this device presents no danger to the rescuer, however, allowance will have to be made, when cutting the top of the B pillar, for an increased diameter and extra metal.

There is a strong possibility that these devices will trigger in a fire situation, given their pyrotechnic nature.

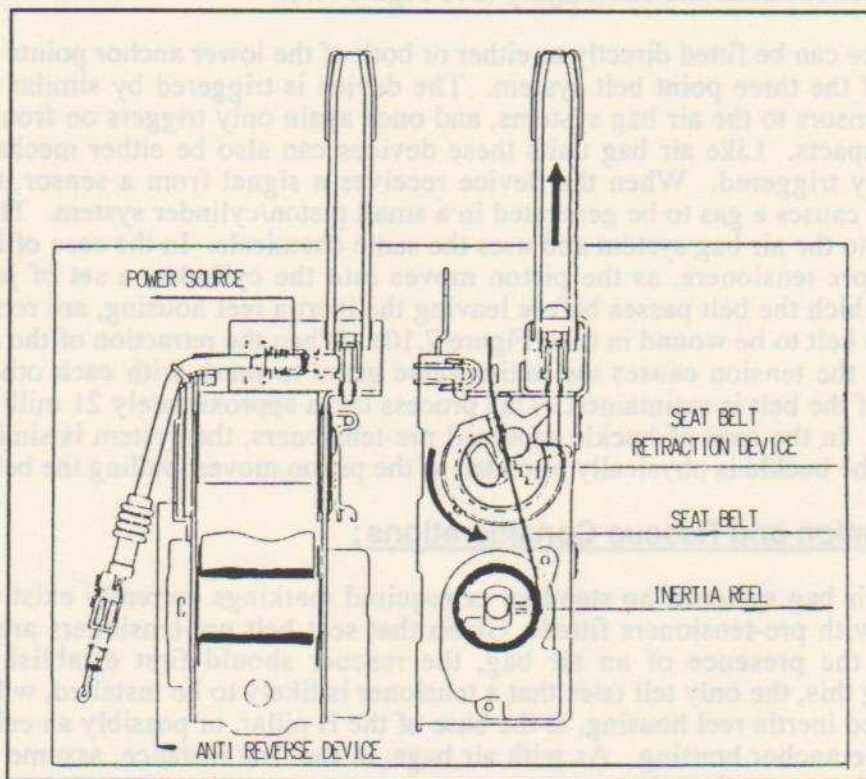

Figure 7.10: When the inertia reel mounted seat belt pre-tensioner is activated, a piston travels up a cylinder forcing a set of jaws to clamp around the belt and rotate, drawing the belt down and tensioning it.

Future Developments:

A number of innovations continue to be made in the field of restraint systems. Research is currently being conducted to identify more energetic (more efficient) air bag inflation gases. Single propellants such as Sodium Azide (SA) and Nitrocellulose (NC) are being superseded by double base propellants such as Nitrocellulose/Nitroglycerine (NC/NG). The advantage of this is a more efficient bag inflation. SA produces approximately 0.4-0.5 litres of gas per gram of solid, while NC/NG generates 1 litre/gram at a temperature of 160°C, instead of 300°C. The hazard from a rescuer and occupant point of view, is that a bi-product of NC/NG systems is the production of Carbon Monoxide (CO) in place of nitrogen.

Current technology has these devices well capable of protecting both the driver and front seat passenger. Similar products are currently being considered for rear seat passengers, and also for side impact collisions. The problems associated with side impact situations primarily relate to the reduced time between initial impact and occupant injury. This could be addressed by building wider vehicles with wider doors, offering a greater buffer zone between the occupant and the striking object.

Another area that will hopefully be addressed by regulatory process is the need for a symbol on the outside of the vehicle, warning of the presence of such pyrotechnic devices.

Summary:

The field of supplementary restraint and air bag protection systems is, without doubt, a rapidly expanding one (no pun intended), and one which has the potential to further traumatise both the casualty and rescue personnel if not addressed properly. First responders to motor vehicle accidents need to be able to identify if an SRS is present and if it has deployed. If not, as will be the case in a number of likely scenarios until technology improves, rescue personnel will need to know how to safely disarm such devices. The content of this section is an overview of some of the systems which exist today, and how to deal with them. It remains for individual rescue services and groups such as CUEES to seek out and disseminate such information to front line rescuers.

The development of supplementary restraint systems is typical of the innovations made by the automotive industry to improve both safety and comfort in passenger and transport vehicles. Implementation of these improvements creates a large number of considerations and potential hazards for rescue and emergency service personnel. It is, therefore, paramount that all personnel maintain a keen interest in such developments in order to keep up with current technology. This will ensure that the best and safest possible assistance is always rendered to the casualty, who is after all, our most important consideration.

The lack of any regulatory requirement to display some form of warning of the presence of SRS equipment generates the potential for serious injury to emergency service personnel in the course of rescue work. The need for placarding in the case of explosive protection systems is well established in the setting of military aircraft ejection seats, and the like. The lack of similar markings on passenger vehicles, despite the much smaller quantity of explosive, nonetheless creates something of an inconsistency. Although not prolific in Australia yet, numbers are steadily on the increase, and before long SRS's will be mandatory in motor cars, as are seat belts. It is hoped that when they do become mandatory, that either Occupational Health and Safety Dangerous Goods regulations or Australian Design Rules for vehicles will ensure the SRS equipped vehicles are placarded in a similar manner to LPG powered vehicles. While this argument could be carried to an extreme, requiring vehicles to display several prominent warning tags, the risk of injury associated with non-detection of a

non-deployed SRS is sufficiently significant for it to be incorporated under a similar banner.

References:

- Air Bags - A Crash Course for Rescue Personnel. [Video] American Coalition for Traffic Safety, 1990.
- Akers, M. A. Steering Wheel Airbags, Additional Occupant Protection. Surrey, England: CUEES, 1992.
- Charles, A.F. Car Air Bags and Seat Belt Tensioners [Speech] 1992.
- de Forest, R. Safety and Roadworthiness. [Speech] 1992.
- Emergency Rescue Guidelines For Air Bag Equipped Cars. Emmitsburg, Maryland: National Highway Traffic Administration, 1991.
- "Growth in Ford Air Bag Applications Continues". Ford Service Training: Technicians Topical Tips. No. 46, 1991.
- Judd, R. Restraint Systems - Airbags and Seat Belts. [Speech] 1992.
- Kidd, J.S. & Czajkowski, J.D. Vehicle Extrication- A Training Manual. Saddle Brook, New Jersey: PennWell Publishing Company, 1991.
- Moore, R.E. Vehicle Rescue and Extrication. St Louis, Missouri: Mosby - Year Book, 1991.
- Saab 9000/900 - Airbag. [Technical Service Information] Saab Motor Company [nd]
- The Mercedes-Benz steering wheel airbag. Germany: Daimler-Benz, [nd].

PART TWO:

RESCUE SERVICE VISITS

During the course of my tour, I availed myself of every opportunity to visit rescue services, not only to examine equipment used, but also to compare training and operational procedures. In each case the rescue capability was provided by the Fire Brigade, and with the exception of the similarity between England and Scotland, all of the approaches differed significantly.

PART TWO:

RESCUE SERVICE VISITS

During the course of my tour, I availed myself of every opportunity to visit rescue services, not only to examine equipment used, but also to compare training and operational procedures. In each case the rescue capability was provided by the Fire Brigade, and with the exception of the similarity between England and Scotland, all of the approaches differed significantly.

BRITISH FIRE SERVICE VISITS

Introduction:

Each municipality, in Britain is obliged to form its own Fire Service. All such services are governed by the British Home Office. Within the Home Office, the Minister responsible for the Fire Services accepts recommendations from a Central Fire Brigades Advisory Council in relation to various matters. Such recommendations include an agreement with the Police to authorise Fire Service personnel to deploy warning signs at road accidents stating "Police Accident". Parliamentary regulations would not normally allow this.

Given the likely delay in response of an emergency tender, due to time and distance constraints (they being less prolific than other fire service appliances), the Council has made various recommendations regarding the equipping of other appliances:

That in the first predetermined attendance to the scene of a road accident fire authorities should ensure that at least one appliance is specially equipped to render help to persons who might be injured or trapped.

The special equipment recommended in addition to the normal gear carried on pumping appliances is:

1. *A set of portable hydraulic lifting and spreading gear with minimum capacity of four tons.*
2. *A metal cutting tool. The choice is open to the fire authority.*
3. *Heavy duty gloves to provide protection against sharp metal edges, broken glass, etc.*

It is generally considered that sufficient lighting is carried aboard most appliances for road rescue requirements.

In the interests of safety, members of the fire service in attendance at road accidents should be provided with conspicuous clothing, including fluorescent orange flame proof turnout coats and yellow over trousers, all with silver reflective strips attached for night visibility.

The concept behind this approach is to allow basic steps such as gaining entry to be taken, while back up services and equipment are responding. The equipment is also useful in general fire duties, for gaining access to buildings, etc.. Given the Fire Services have no legislated responsibility to provide a rescue service, there is no obligation to abide by these recommendations, most Services however, do.

During my tour, three quite different British Fire Services were visited.



Figure 8.1: Strathclyde Fire Service Heavy Rescue Vehicle.

Strathclyde Fire Service:

The Strathclyde Fire Service is based in Glasgow, Scotland, and covers an area of some 350 square miles (approx. 900 square kilometres), stretching north from Glasgow, and including some 18 islands. The Service is staffed by both full time employees and retained members¹. Strathclyde also operates its own training school, and may definitely be placed in the pro-active category with respect to rescue.

To cover their area of responsibility from a road rescue perspective, the Service has a triple layer system in place. At the first level, is every fireman and appliance. Basic training for all personnel includes an introduction to rescue tools and techniques. Each fire tender carries a hydraulic spreader and cutter operated by a hand pump, in accordance with the recommendations outlined above.

Level two of the system consists of rapid response rescue vehicles, six of which are distributed around the brigade. These vehicles are light vans akin to a large Hiace van or similar. The vehicle is crewed by 2 personnel, and not only responds to any road traffic accident involving persons trapped, but also serves as a prime mover for any specialist trailers which may be required. These include a breathing apparatus (BA) control trailer, a foam trailer and an inflatable rubber boat (IRB) for flood and water operations. The equipment carried aboard this vehicle (See Annex C.1) is not as

¹ Retained staff are available on pager when required and paid only when called.

extensive as that required by Victorian rescue units under the Combined Emergency Services Accreditation Standard. It should be noted that the extent of equipment on this vehicle is limited because it has the backup of the third level of the system.

Level three is a single Heavy Rescue Vehicle (HRV). This vehicle is similar in size to a large furniture removal van, and is in fact known colloquially as such within the Strathclyde Fire Service! The vehicle was established following four major incidents involving rescue and extrication. They were:

- Two major rail accidents, involving a number of fatalities and trapped persons;
- A 12 storey building collapse which resulted from a helicopter hitting the building; and
- The Lockerbie air disaster, in which Strathclyde provided support to the local brigade.

The vehicle is not only a local resource, but is available on a national basis, to support any defined 'Major Incident', when requested.

The vehicle responds with a crew of two who are responsible for maintaining and registering the deployment of its equipment. The vehicle carries an extensive range of equipment, with sufficient reserves to outfit six teams (see Annex C.2). Brigade Standard Operating Procedures (SOP) also dictate that a pumper and crew of five from the same station will always travel with the vehicle, irrespective of where it is deployed. This guarantees a trained crew to operate the equipment. If necessary, each member of this crew, can lead a team of personnel in the use of the equipment. If the pumper and crew are on another fire call when the HRV is requested, they will be relieved at that scene, to allow response. This is a short term measure, until further crews are trained to work with the HRV.

Criteria for deployment of the HRV on a 'First Attendance' call are:

1. 5 pumping appliances, or more attending the call. In this case the HRV supporting pumper will not be mobilised unless known rescues are involved.
2. Implementation of the disaster plan.
3. A defined Major Incident.
4. Multiple vehicle accident involving 3 cars or more.
5. Road traffic accident involving heavy goods vehicles.
6. Collapsed buildings.
7. Accidents involving trains, especially in the underground network.
8. Accident involving aircraft, away from airports.
9. Aircraft accidents or imminent accidents at Glasgow or Prestwick airports. The predetermined attendance at these incidents will also include a light rescue tender.
10. Accident involving persons trapped in sewers or heavy machinery.
11. Incidents involving rescue from high aerial structures.

The HRV is also available on request of the officer in charge of any incident, if he requires it.

Greater Manchester Council Fire Service (GMCFS):

The GMCFS covers the greater Manchester area, providing a service to a city of over 700,000 people. It operates in a similar manner to Strathclyde, with the exception of not having an HRV at its disposal. The GMCFS pumpers carry a more extensive range of tools than recommended by the Home Office's Advisory Council (See Annex C.3), with their emergency tenders fulfilling a role somewhere between that of the light and heavy rescue vehicles of the Strathclyde Fire Service. The GMCFS is also active in the field of road rescue training, having developed a pilot instructors course, which was running during my visit.

The road rescue instructors course is one week in duration and aimed at Junior Officers, that is shift commanders on station. At the end of the course, students will be expected to return to their station and conduct training for other personnel on that station. The course is facilitated by the instructors of the GMCFS Training College, but students are encouraged to teach one another and share ideas. At their disposal, to develop lessons, are all the facilities of the training college, including a PC based computer aided teaching package capable of developing animated sequences for projection onto large screens, depicting any particular teaching point.

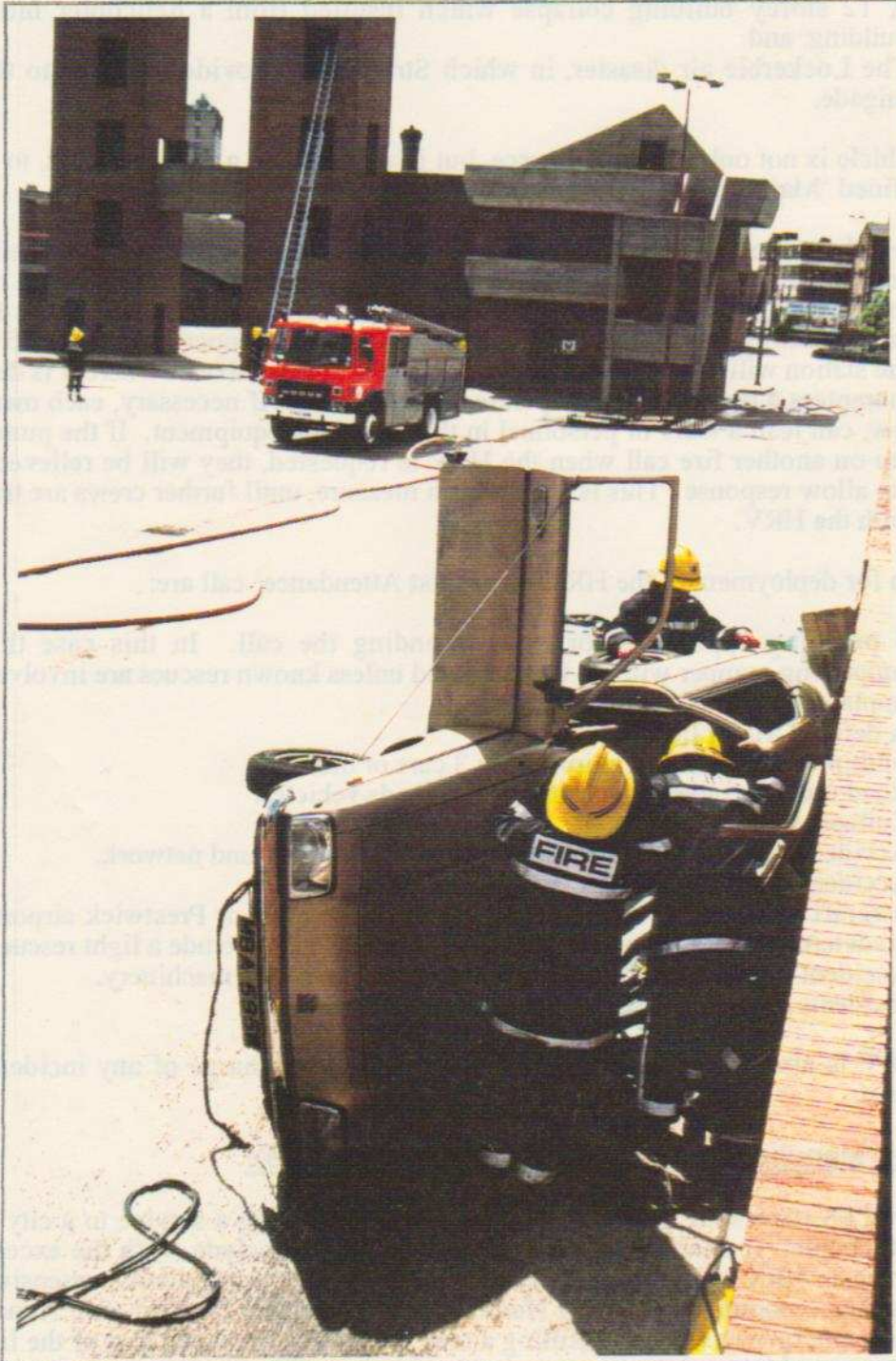

Figure 8.2: Greater Manchester Fire Service Road Accident Rescue Training Course.

The course syllabus covers:

- Relevant legislation relating to agency responsibility
- Motorway procedures
- Incident approach and safety
- Appliance positioning
- Fire and explosion hazards in vehicle accidents
- Hazardous materials
- Fatality identification tagging systems
- Vehicle stabilisation
- Vehicle construction
- Heavy vehicle construction
- First aid & Casualty handling
- Tool operation
- Rescue Techniques

It is fully supported by a training manual, issued to all participating members. It is interesting to note the lack of such subjects as Critical Incident Stress management and the like. Discussions with the training college staff revealed that little has been done in this area as yet.

Merseyside Fire Service:

Here there is a different perspective in the approach to rescue in Britain. Merseyside is a largely industrialised area near Liverpool and incorporates one of the largest sea ports in Britain. The Merseyside Fire Service has therefore to contend with a number of local hazards that other services may not face. These include potential fire and rescue situations aboard ships, both while docked, and in the harbour. Another significant factor is the movement of radioactive material through the harbour. emergency tenders therefore carry appropriate equipment for incidents such as these.

Like most other brigades in Britain, Merseyside conforms to the Home Office recommendations and carries a basic set of tools on its front line fire tenders. Merseyside has elected, in fact, to place a limited amount of motorised tools on all pumpers (See Annex C.4).

The pumpers are backed up by specialised emergency/rescue tenders. In the case of Merseyside, the particular appliance shown to me was a combination emergency tender and control unit, soon to be retired from service. The vehicle is similar in size to a double decker bus, and is fitted out internally to allow both operational control and BA control to be undertaken simultaneously. External compartments and other available spaces, such as under stairs and the like, house a broad ranging set of rescue tools (See Annex C.5).

When the vehicle is retired from service, it will be replaced by a long wheel base prime mover and a series of demountable pods. Various pods are in the development phase, including rescue, heavy rescue and control modules, as well as various fire specific pods such as BA and foam. Each will be self contained, and can be delivered to and left on site if required. This has met with mixed feeling from the members of the Service, with concerns being expressed in relation to delayed response due to the need to 'mount up' the appropriate pod. One member of the crew on duty at the station I visited made comment in relation to the type of rescue tools supplied on the pumper and the proposed new pods, that:

"A crow bar and some brute force will often do the trick, we don't need this sophisticated equipment!"

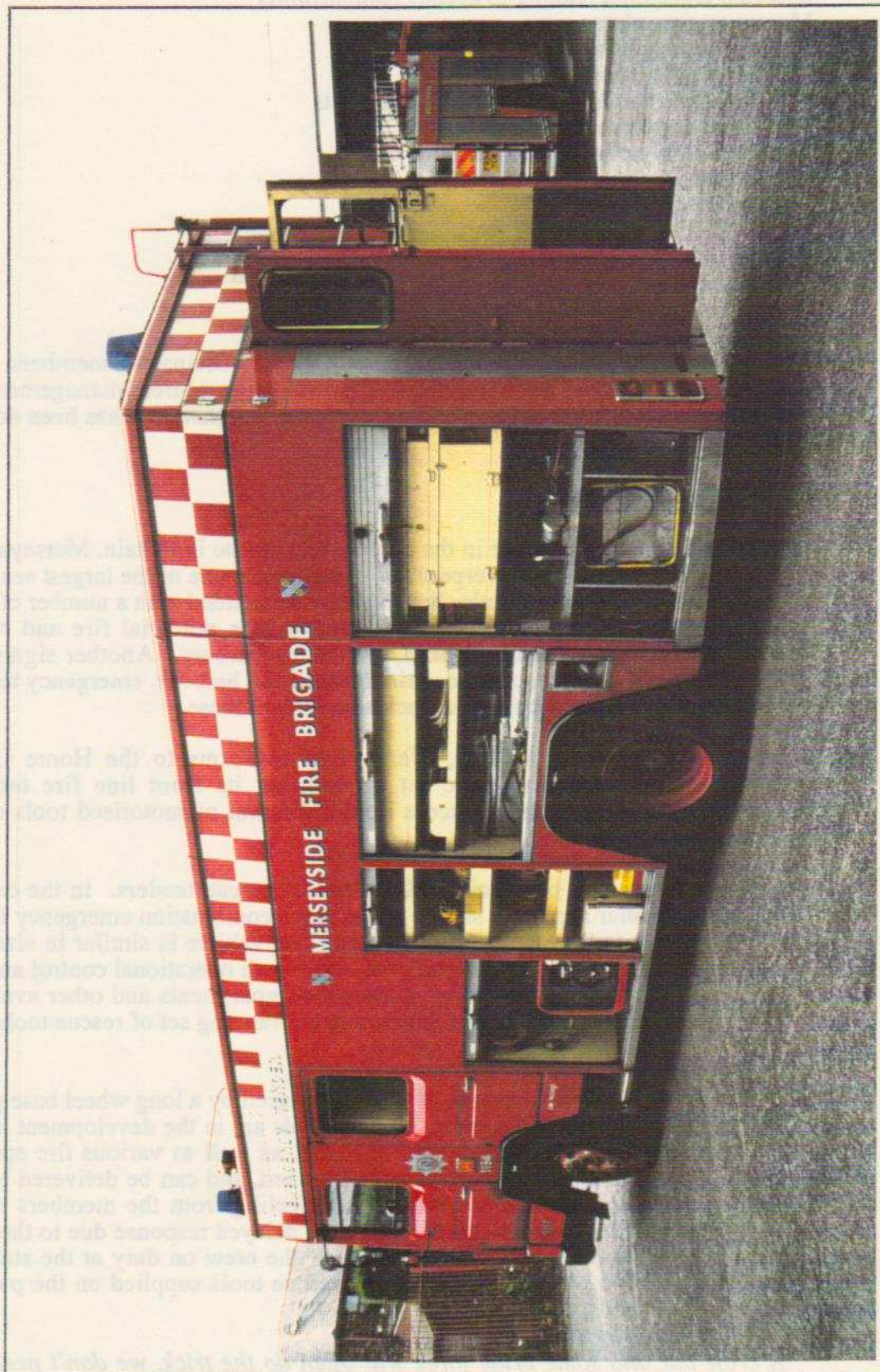

Figure 8.3: Merseyside Fire Service Emergency/Control Tender.

This tends to suggest that either there is some unrest or lack of interest (or basic training) as a result of the proposed changes within the Merseyside Fire Service.

Summary:

The British Fire Services, albeit without the support of legislation have established, what appears to be an effective layered system in their response to extrication. The concept of all pumping appliances carrying 'First aid' rescue tools to allow initial access for patient care while a back up rescue tender responds, appears logical and supports a reasonable attempt to work within the Golden Hour philosophy.

Equipment and training levels, as well as attitudes appear to vary significantly from one brigade to the next (based on the limited visits undertaken). Indications are that this is largely dependant upon the level of enthusiasm expressed by the senior officers of the brigade. Despite this, the more innovative brigades are developing new ideas through training programs and equipment and vehicle acquisition programs, that go far beyond the recommendation of their controlling body. This would tend to suggest that both the funding and commitment to rescue by the British Fire Services is strong.

CONTINENTAL RESCUE SERVICE VISITS

Despite closer political and economic ties in Europe today, it is not surprising that little has occurred at the coal face between rescue services to standardise their approach to equipment, training or techniques. During the course of my tour, I visited rescue services from three countries, and found their approach to be as different as their cultures.

Brigade de Sapeurs - Pompiers de Paris Paris Fire Brigade - France:

The Paris Fire Brigade (PFB) is unique in the world for many reasons. It is the only military based fire service that answers to the Prefect of Police¹, as part of its chain of command, and provides a full time fire/rescue services to the general public. Like all military organisations, it has a motto:

"To save or to Perish".

The history of the PFB stretches back to 1811, when Emperor Napoleon I, ordered one his Generals to take command of a regiment to provide fire protection to the citizens of Paris. It is from this background that the current service to Paris and its sister service in Marseilles has developed. All other fire and rescue service in France are civilian based.

All personnel in the PFB are members of the army, usually from the corps of engineers, although many come from the National Service intake². As a result a very different approach is taken to both the structure of the organisation and to the functions it performs. For example, each station is run like a military unit, with rent free accommodation provided for the officers and men and their families on station.

The organisation is largely self regulating, and the roles and responsibilities of the PFB have extended, in much the same way as many American fire/rescue services, to provide a number of different services. The PFB roles include:

- Fire and hazardous material response, including pollution control;
- Road rescue, including the clearing of roads following minor accidents;
- Rescue from heights;
- First response paramedical treatment of casualties (this is supported by radio diagnosis and direction of treatment from a 24 hour roster of army doctors);
- Response to animal accidents, both for treatment and 'Neutralisation';
- Isolation of utilities services in emergency situations; and
- Urban search and rescue, especially in drains and the underground rail network.

¹ Under French law the Prefect of Police is charged with responsibility for protection of persons and property, including against fire, in Paris and surrounding areas.

² All eligible French citizens over the age of eighteen are obliged to undertake 10 months military service. This provides a steady flow of personnel to undertake duty with the Fire Service.



Figure 9.1: Paris Fire Service Rescue Appliance.

The PFB employs 7100 personnel to cover the city of Paris and surrounding districts, which comprises an area of 760 square kilometres and a population of over 6.5 million people. These personnel are based at 81 stations in three zones across the city and respond to over 300,000 calls per year.

The PFB operates a first response vehicle, similar to a Bedford van. This vehicle has both a fire and medical role, carrying a crew of five, 1000 litres of water, and a stretcher for casualties. transport will, however, only take place on the authorisation of a doctor. This is normally the role of the Ambulance Service.

From a rescue perspective, the PFB operates six specialist appliances, two based at each of three mechanical workshops. There is one workshop in each of the three fire zones of Paris. Unlike the British Fire Service layered approach, the Parisians have adopted an all or nothing view. The PFB maintain all their own equipment and vehicles at these workshops, which are staffed by army personnel who are qualified mechanics. The personnel stationed at these workshops, also crew the rescue vehicles and other specialist appliances, thus giving a sound mechanical knowledge for extrication. This, however, would appear to be the limit of training undertaken in the field of extrication. There is no specialist extrication training other than in the operation of the tools. That is, no consideration is given for a systems approach, vehicle stabilisation, or protection of the casualty. This is quite amazing, given the way the average Parisian drives!

The rescue appliances are similar in size to a short wheel base, single cab Mazda T4000, and carry a range of tools, many of which are electrically operated. The vehicles includes a large PTO operated 10kVA generator, and switchboard. This set up, which has a self governing rpm controller, is capable of running up to eight 500W lights, as well as either an electric over hydraulic pump for extrication tools, or a plasma cutter³. The disadvantage of this tool, apart from the sparks generated, is that it requires earthing, therefore an earth line must be attached to the rescue tender before operation can begin. A range of other tools is also carried (See Annex D.1).

Breda Brandweer **Breda Fire Service - Holland:**

The Dutch Fire Services contrast that of Paris significantly, and in fact are probably the closest both in training standards and responsibilities to VICSES of all the services visited.

Like Britain, each municipality in Holland is responsible for raising its own Fire Service. In Breda, a city of 125,000 people, the fire rescue service is provided by one station, with a full time staff of 64, working in four shifts. They are backed up by a small army of volunteers on a paging system. The Breda Fire Service, has responsibility not only for fire and land rescue, but also for water rescue, pollution/radiation monitoring and civil defence and counter disaster planning. The fire service does not undertake any medically related activities other than basic first aid, to support the Ambulance service. The water rescue activities include diving, but due to the polluted nature of most water ways, wet suits and standard regulator mouth pieces are not used. Only full enclosed 'dry suits' and full face masks are considered acceptable under local occupational health and safety requirements.

The volunteers train on a fortnightly basis, and their training covers all aspects of Breda's responsibility, like the permanent staff the volunteers are all multi skilled. All training is on a modular basis, complete with lessons, work books and examinations. When each member (either permanent or volunteer) of the brigade passes a section they are certified and their records endorsed accordingly. The training is structured so that

3 A compressed oxygen supplemented arc welder.

various modules can only be attempted after other base line segments have been completed, or a certain rank attained. The rescue training syllabus includes:

- Very detailed lessons on each tool, including the ability to strip the tool, identify parts and fault find, before techniques for use of the tool are learned;
- Building collapse, shoring and searching;
- Command and leadership;
- Knots, lashings and field machines;
- Casualty handling and stretchering;
- Rescue from heights;
- Extrication techniques;
- Lift shaft rescue;
- Hazardous material identification;
- Storm damage and animal rescue;
- Incident approach and vehicle positioning; and
- Radiation monitoring.

The training program has also seen the introduction of a critical incident stress program in association with the Police department, following a major road traffic accident.

From a counter disaster planning perspective, the Chief Officer of the Fire service is the designated Displan Coordinator, and the Police force are required to put their requests through him. Accordingly, he is responsible for the development of emergency management plans to deal with identified hazards. This has led not only to a predetermined time and equipment response to every building, both domestic and industrial in the city, but also to the development of a special plan for days of severe fog. Because of Holland's flat topography, it suffers significantly from severe fogs. This has resulted in numerous major freeway accidents. One such incident in Breda's area of responsibility, involved 108 vehicles, claimed 8 lives and injured 27 others. As a result, days of severe fog in Holland tend to be treated in a similar manner to days of total fire ban in Victoria, with an increased crew present at the fire station and speed restrictions on the freeways.

Like Britain, Breda's front line pumpers carry a basic set of rescue tools, including a double acting combination tool, and motorised pump. To back this up is a heavy rescue vehicle, similar in size to a Melbourne Metropolitan Fire Brigade rescue appliance. This carries a range of rescue equipment (See Annex D.2) and like all other appliances, is fitted with yellow flashing lights in addition to the standard blue. Local standard operating procedures require that once on scene, all blue lights are turned off, and yellow ones, indicating a hazard, are turned on.

Tilburg Brandweer **Tilburg Fire Service - Holland:**

Tilburg is a similar sized city to Breda, some minutes away. The Tilburg Fire service is similar in command structure, staffing, equipment and training syllabus to that of Breda. Road rescue training is, however, handled as a separate subject, after basic training. To gain certification in the field of road rescue at Tilburg requires 120 hours of training, one night per week for 30 weeks. Permanent staff and volunteers work a 24 hour shift at the station. This comprises 8 hours sleep, 8 hours recreation and 8 hours drill or work in the workshops attached to the station. Rostered shifts for full time staff are two days on two days off. Between drill and fire calls, the duty crew assist civilian staff in any one of the mechanical, carpentry, plumbing and fitting or painting workshops. These workshop have responsibility for maintaining the fleet of local government and emergency service vehicles, as well as taking on any other contract work in the area.



Figure 9.2: Erlangen City Fire Service Heavy Rescue Tender.

Stadtfeuerwehr Erlangen Erlangen City Fire Service - Germany:

Federal law in Germany requires each municipality or designated area to provide a fire/rescue service. How the local government chooses to carry this out is largely a matter for them, based on their finances. This technically allows private fire services to exist. In general four types of fire brigade exist in Germany: Professional (full time), Volunteer, Industrial (sponsored by a particular company for fire protection of their plant) and Permanently present, a lower form of professional⁴. Erlangen falls into the last category, having one permanently manned station in the main city, and relies on volunteer staffed stations in the smaller surrounding villages for support. The Erlangen Fire Service provides both a fire and rescue service, including water rescue for the nearby major shipping canal. This canal which has only just recently opened, was constructed to join the Main (a tributary of the Rhine) and Danube rivers, thereby connecting the North Sea to the Black Sea.

⁴ All cities other than the big three (Munich, Hamburg and Cologne) are only eligible for permanently present fire services. This means less funding, and little or no backup personnel, unlike the full professional services.

The brigade has no fixed training program, although the state government (Bavaria in this case) produces standard training packages, as a guide in much the same way as the Dutch authorities do. The general feeling from local personnel is that these training packages are written by 'Textbook experts', who have little practical experience. They are therefore difficult to implement, and as a result are used with some licence. Often the training program is tailored to meet local needs. Training (after basic induction) for both the full time and volunteer members, is about 1 to 1.5 hours per week, and usually subject to available funds. Some training is done by sending personnel to company based training courses, with the expectation that they then return to teach the remainder of the brigade, again subject to available funds.

Fire services fall under the municipality's department of safety, and funding is supplied by both the local and state government. The municipality provides the operating budget for the fire service which tends to be somewhat politically motivated depending on the Mayor of the day. The state provides limited funding in the form of standard equipment issues, to all brigades. These are based on the German DIN standards, with financial support only being given to purchases that fall in line with those standards.

The Erlangen Fire Service operates a rapid response road rescue vehicle, in the form of a Mercedes Galanda wagon. This vehicle has a minimum of extrication equipment aboard (See Annex D.3). The service also has a heavy salvage/rescue vehicle, similar in size to a Melbourne Metropolitan Fire Brigade rescue tender, with a large array of equipment aboard (See Annex D.4). Although the rapid response vehicle, which was developed locally, has proven its worth, it has also identified another problem. Erlangen Fire Service is turned out by a main control room in Nuremberg a major city some distance away. In Nuremberg the Red Cross provide both the paramedical aid at a scene, and transport the casualty to hospital. Within the local Erlangen area, Red Cross only treat, they do not transport, this is left to a local Ambulance Service. As a consequence, when the rapid response vehicle arrives, on scene, often ahead of the Ambulance, and sometimes ahead of the Red Cross, the EMT⁵ trained rescue crew is faced with a dilemma. Firstly in relation to treatment, and secondly in relation to transport of the casualties. This principally stems from a lack of defined local coordination system at the scene.

Werkfeuerwehr Flughafen Nürnberg: **Nuremberg Airport Fire/Rescue Service - Germany:**

Nuremberg International Airport, is designated German Federal land, and as such all personnel employed by the airport authority are federal employees. The Nuremberg Airport Fire/Rescue Service, therefore operates in a similar manner to their sister organisations in Australia. As a result of recent municipal legislative changes, the area of responsibility of the Airport Fire Service has been extended to include all buildings, roads and installations on airport land, as well as the traditional aircraft role. This comes about as a result in a shift of interpretation of federal laws requiring each area to have a designated fire service.

The Airport Fire Service has a legislated mutual aid arrangement with the Nuremberg city brigade for back up, which is a one way arrangement, that is, the airport fire service has no responsibility to back up the city brigade. The two services share a common radio frequency. A response plan, which identifies the role of the city brigade, in the event of a major incident, is currently being prepared.

⁵ EMT stands for Emergency Medical Technician. An American layered system for training paramedical personnel.

Training in all aspects of the Service's responsibility is conducted on a monthly basis for all personnel. Each member must take part in training on every piece of equipment every six months. Aircraft rescue does however, present a problem, because of a lack of aircraft, so cars and buses are often substituted.

The Service rescue (or Technical Services) vehicle is similar in size to most of the other heavy rescue/salvage vehicles seen. It responds with a crew of six and is well equipped for gaining rapid entry to either aircraft or motor vehicles. Like all airport tenders, its main asset is acceleration, allowing it travel quickly the length of the runway.

Nuremberg airport averages 200 aircraft arrivals and departures per day. In 1991, the Fire Service had a total of 1500 turnouts to all incidents types including false alarms. Figures for 1992, with the increased area of responsibility are likely to be near double.

Summary:

Although the five visits I undertook gives only a small glimpse of the overall European rescue structure, it does highlight several points:

1. There appears to be no common standards at either legislative or rescue service level between the countries visited, and in some cases, within them.
2. Despite equipment being plentiful and modern in all cases, the level of funding for replacement appears to vary dramatically.
3. The response approach varies from one country to the next, and this can be attributed to a combination of local area operational procedures and available funding. The French have adopted an all or nothing approach, much like most of Australia, although only through self regulation, with a single rescue vehicle. Both the Dutch and Germans, have however, adopted a similar capability to that seen in Britain, with 'First aid' equipment being carried on most vehicles, with back up of heavier rescue appliances available if required.
4. The amount and degree of training varies significantly from the almost non-existent in Paris, through the average in Germany, to the thorough in Holland. It is arguable that the Dutch training level may in fact be more extensive than that required by the Victorian Combined Emergency Services Accreditation Standard in some tool related areas. However, with this exception, Victorian rescue services would appear to clearly stand equal to or lead the other services



Figure 9.1: Nuremberg Airport Fire/Rescue Service
Technical Services Tender



Figure 9.3: Nuremberg Airport Fire/Rescue Service Technical Services Tender.

PART THREE:

COMPANIES AND EQUIPMENT

During the course of this study tour I visited a number of manufacturers and one distributor of rescue tools. In each case I was very warmly received and able to discuss and view at length the various tools and their applications. This included in most cases viewing the manufacturing and quality control processes employed in the production of the tools. As a consequence, I have a much broader understanding of the technical side of the hydraulic rescue tools.

**COMPANY
VISITS****Introduction:**

In Europe today, there are some eight to ten recognised manufacturers of hydraulic rescue tools, most of whom have either a subsidiary producing air operated tools, or have an agreed marketing partnership with a similar company. Of the hydraulic tool companies, I was able to visit two, as well as attend a two day course in basic hydraulic rescue tool design, fault finding and maintenance. This was conducted by the British agent for Lukas. In each case I was warmly received and able to discuss and view at length the various tools and their applications. This included viewing the manufacturing and quality control processes employed in the production of the tools.

A visit to an air bag manufacturer identified standards that apply to the routine testing of such tools overseas, and raises the question of whether a similar need exists in Australia.

**Vepro - Air Bag Manufacturers
Zülpich, Germany:**

The Vepro company is relatively new in the field of rescue tool manufacture having been formed by Herr Vetter in 1980, in direct competition with his very successful Vetter air bag manufacturing plant. This, I was told, was a deliberate business manoeuvre to corner parts of the market his first company had been unsuccessful with! Despite, or perhaps because of, this cunning business sense, I was not allowed to view the manufacturing process, because of his fear of industrial espionage! Discussions and demonstrations were nonetheless fruitful.

Vepro manufactures a range of air bags including high pressure, low pressure, pipe and leak sealers and aircraft lifting bags. The bags are manufactured in either steel cored or kevlar, with both types being covered in vulcanised rubber. Although one or two other air bag manufacturers use similar processes to produce their bags, a significant number of others use a process of folding and gluing rubber, much like a football bladder. This process produces a bag with a lesser lifting capacity to volume ratio.

Vepro's range of low pressure, or recovery type air bags, operate at significantly lower pressures¹ than the traditional lifting bags. In order to ensure bags are not inflated beyond their normal working pressures (by connection to a high pressure source), a different form of coupling and large diameter hose system is used compared with that on the high pressure bags. This is a marked difference from other manufacturers of air bags, most of which tend to use the same coupling. Vepro uses a 'Michigan Glad Hand' type connector for its low pressure air bags, and also supplies a range of adaptors to allow the low pressure air bag regulator to be connected to several different air

¹ Pressures are usually 0.5 bar, but can be 1.0 bar. For comparison purposes, an inflatable rubber boat normally operates at about 0.2 bar.

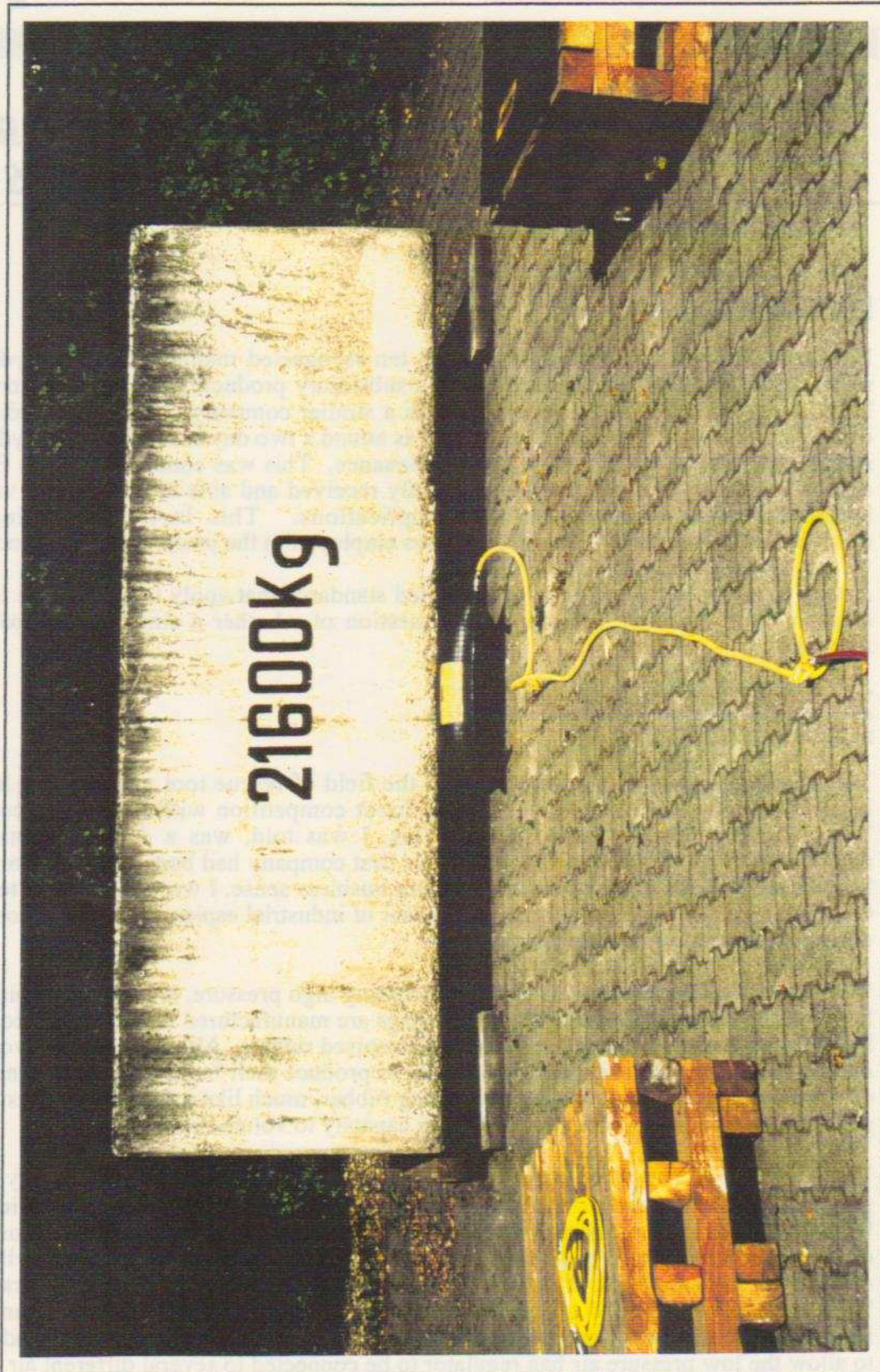

Figure 10.1: Vepro High Pressure Air Bag at work.

sources including heavy vehicle air brake compressors, spare truck wheel, etc. The low pressure bags are available in the conventional configuration for lifting bags (i.e. two flat sheets joined at a single edge seam - cushion style), or with separate side walls, allowing significantly higher inflation and lifting (i.e. cube style). This style also costs considerably more. Low pressure bags with side walls included can also be produced with internal ropes joining top and bottom surfaces to avoid over expansion of the bag. These bags require more careful placement before inflation to ensure the load is brought to bear more evenly. All low pressure air bags are repairable with patch kits.

Vepro manufacture its full range of high pressure air bags in a kevlar construction, because there is a market for them. They do not, however, recommend them except in weight dependant situations. Kevlar bags are lighter than steel core, but not as strong, and are normally expected to last 10 years compared with 15 years for steel bags. Despite being lighter and more flexible (because of a lack of steel), the kevlar bags offer few advantages, and cost the same to manufacture. The only potential problem with the steel core bags is in the manufacturing process. It is necessary to ensure that there is an air tight seal between the bladder chamber and the steel during vulcanisation. If there is not, water ingress will cause contamination, thereby promoting oxidation (rusting) and will reduce the life of the bag. Warranties on the two different constructions are 12 months for Kevlar, and 3 years for steel cored.

There has been no recorded incident of a bag bursting. Any problem with an air bag will show in the form of an aneurism on the external surface. As described above the main problem with high pressure air bags occurs with vulcanisation, that is a failure of the rubber to adhere to either the steel core, or the Kevlar as the case may be. Usage problems can occur with bag/hose couplings. Connectors can be replaced if they break, provided they do not damage the seat of the nipple receiver in the rubber of the bag. Failure of this connection may be related to the moisture content of the air on the day of manufacture (Once again a problem related to vulcanisation). Filling the bags with water in place of air to gain greater lifting capacity² will not have a significant effect on deterioration of the bag, unless a manufacturing defect has occurred. Vepro assured me that their quality control process will identify any such faults prior to the bag leaving the factory, given that each bag is individually tested. I was, however, unable to view the process.

Vepro indicated that they would now be producing high pressure bags in black rubber, instead of the traditional blue, because the blue colour fades in sun light and shows dirt. This change is purely a cosmetic one.

Discussions with Vepro staff revealed that in Germany, air bags used for lifting are considered to be pressure vessels and therefore are subject to TUV (similar to Occupational Health and Safety Authority) approval for manufacture, use and routine hydrostatic testing. Every 5 years bags are required to undergo a pressure test, and after 10 years, annually. This regulation applies to high pressure bags only, because the regulation is based on a formula:

$$P * V < 200 \text{ kN.m}$$

which exempts low pressure bags. Pipe stoppers are also exempt from the regulation, because they do not lift.

The logical question to ask as a result of this information being exposed, is 'Does this apply in Australia, and if not, should it?' If so, the cost in testing such equipment for all emergency services involved in its use could be quite staggering. Further to this, how many bags are in active use in the system, and of those, how many now have questionable integrity, due to age and/or condition?

² Filling bags with water instead of air will increase lifting capacity by approximately 1/3.

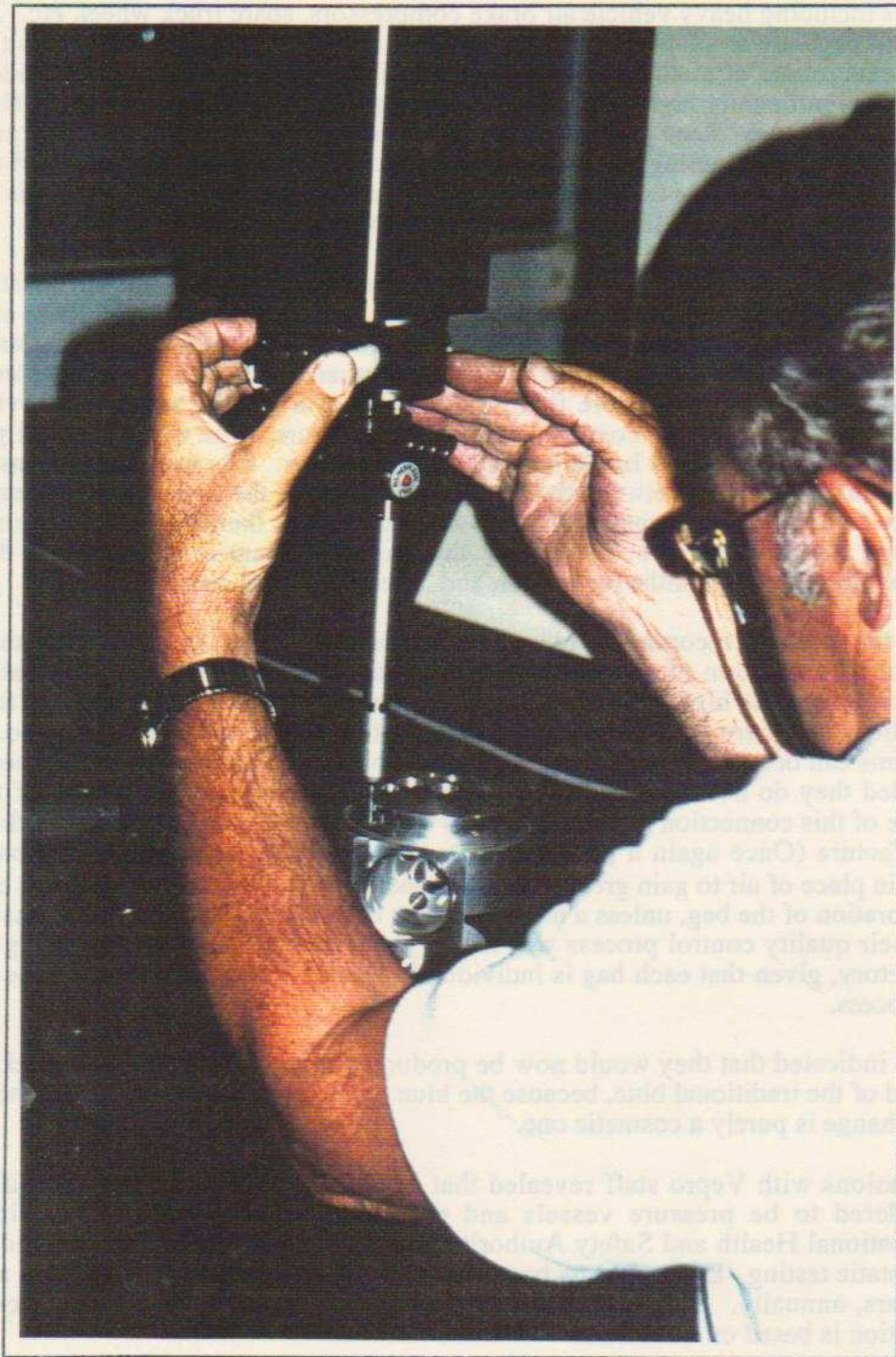

Figure 10.2: Quality Control at Halmatro involves use of a 'High-Tech' infra red laser measurement system.

**Halmatro Industrial & Rescue Equipment
Raamsdonksveer, Holland:**

Halmatro is one of the major manufacturers of hydraulic rescue tools in the world with sales in over 100 countries. The company prides itself not only on its after sales service, assistance and hospitality, but in particular on its 'Modern technology' approach with respect to manufacture and quality control. All tools are produced using

computer aided design (CAD) and numerical control manufacture (NCM) techniques, and quality control and specification testing is carried out using the latest infra red laser measuring systems.

The company manufactures a range of industrial and rescue tools, including both single acting and double acting hydraulic equipment, as well as a range of both low and high pressure air bags, and an assortment of assistance tools such as pedal cutters, nutcrackers and pipe sealers. Throughout all areas of manufacture, close attention is paid to compliance with national and international standards where they exist.

Halmatro's tool distribution for rescue purposes, extends beyond the road rescue field and includes civil defence situations such as the earthquakes in Armenia and San Francisco, and underground mining incidents in Poland.

In a road rescue setting the emphasis of this company like many others appears to be shifting toward small lightweight tool combinations for what the European market has termed: '*Rapid Intervention*'. To fill this growing area in the market, Halmatro has manufactured a system consisting of a combination tool³, a small ram and powered by a lightweight petrol over hydraulic pump. The whole system is capable of being transported by one person, weighing in at only 40kg. Such a system provides for rapid access to casualties for stabilisation while a back up rescue unit travels to the scene. Such equipment is ideal for use in confined spaces. One of the disadvantages of such a system is the limited spreading/pulling capacity of the combination tool. This can be particularly significant during steering column lifts. Halmatro have made steps to overcome this by including in the kit a ratchet belt for pre-tensioning the system prior to attempting to displace the steering column.

Lukas Rescue Tools - FAG Kugelfischer Erlangen, Germany:

Lukas is an arm of the large German multi-national FAG Kugelfischer, a major manufacturer of industrial equipment and tools, principally centering on bearings. By contrast with the relatively small Halmatro company, which employs about 100 personnel at its manufacturing plant, FAG employs nearly 35,000 across Germany in manufacturing alone.

During the course of a tour of the manufacturing facility, the full range of Lukas products was discussed. This included both single and double acting hydraulic rescue tools, as well as a range of industrial products and re-railing and righting equipment for train carriages and locomotives. A full demonstration of all the double acting tools comparing different spreaders, cutters and rams was also provided. This revealed several interesting features of the various tools, including, that of the dedicated cutting tools, those with straight blades appeared to twist while cutting more than the traditionally curved blade cutters. This may, however, have been an operator related problem. The straight bladed cutters also appeared to cause the stored energy associated with the object being cut to be released forcefully. This is unlike the usually controlled discharge of stored energy which has always been associated with the Lukas curved blade cutter.

A number of new tools were also demonstrated by Lukas, these ranged from the very large to the very small. At the large end of the scale is the soon to be released LSP100 spreaders. This tool, at nearly one metre in length, is a super heavy duty spreader, designed for two person operation, and is capable of creating openings nearly one metre in size. In the area of cutters, a variation of the tool has been produced with one curved

³ A combination tool performs both the spreading and cutting functions of hydraulic rescue equipment, by employing a specially designed jaw, that has a cutting blade on the inside and a spreading tip on the outside.

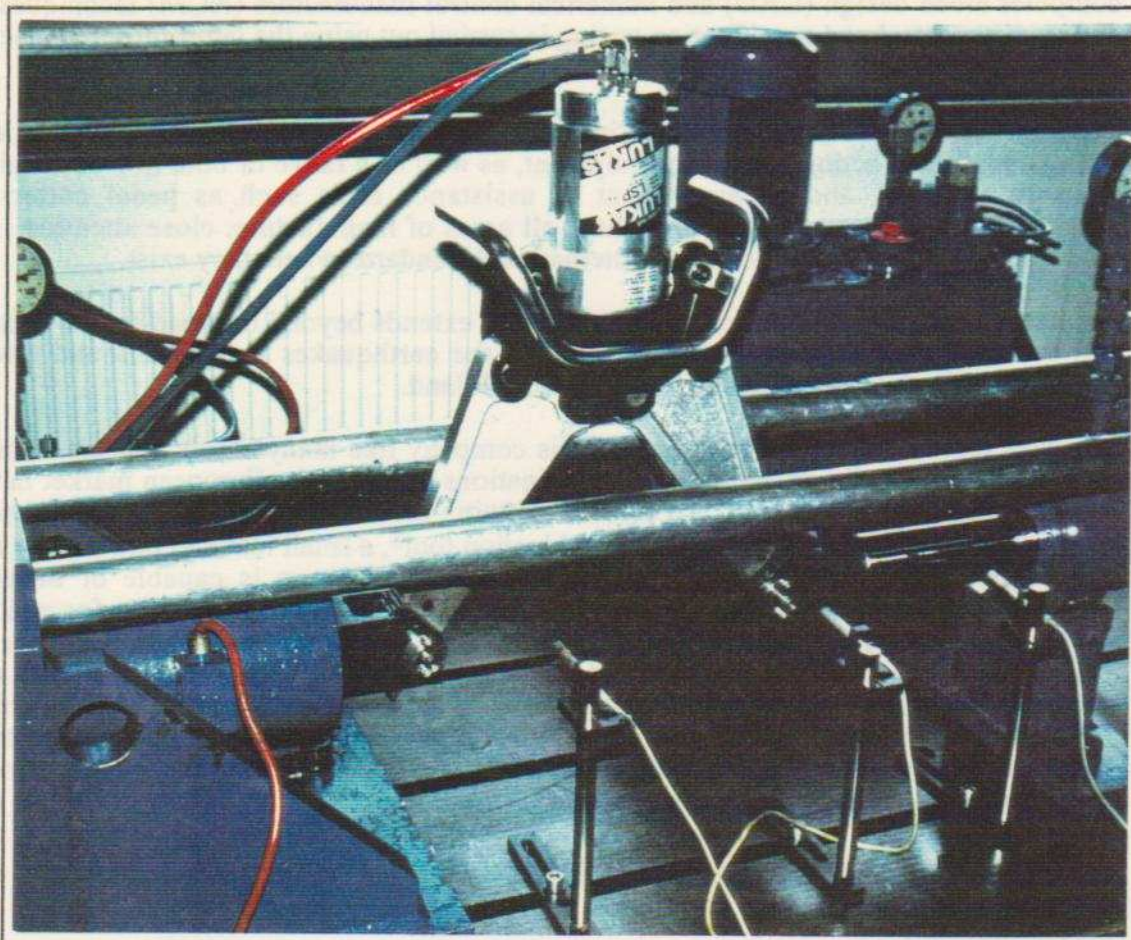

Figure 10.3: Lukas Final Quality Assurance on assembled tool.

and one straight serrated blade. The advantages of this tool are unclear, except the serrations may reduce tool slip marginally from that experienced with two curved blades. A new version of the Lukas ripping set (ram) is currently being developed, which will pierce and tear sheet metal up to 8mm thick. The final tool development shown is another move toward the 'Rapid Intervention' philosophy. Like Halmatro, Lukas has combination tools and small, lightweight pumps. They have also developed a small hand pump operated, double acting, combination tool. This all in one, hand held unit is about 75 cm long and consists of a combination tool at one end, with a hand pump attached on the other. To control the movement (either cut/close or spread/open), a small control valve is built into the unit. The tool weighs less than 12 kg and has a spreading force of 2.8 tonne at the tips and a cutting force of 13 tonne.

At Lukas, the quality assurance and manufacturing processes are not as widely automated as Halmatro. All manufacturing and measuring tools (drill bits, micrometers and callipers, etc.) are calibrated on site by a specially certified laboratory. All incoming raw materials are randomly sampled and tested and all records are kept on computer by batch number. Each employee in the manufacturing process is responsible for his/her own quality control, with a supervisor doing spot checks. All the tools used in this process have been routinely calibrated by their laboratory prior to use. Every assembled hydraulic tool is then put through a quality control check again before leaving the factory. Throughout the whole process, the emphasis is on the 'hand made' quality and workmanship, much like Rolls Royce. Manufacturing precision for piston/cylinder systems is claimed to allow tolerances no greater than one micron.

Clan Tools & Plant Ltd **Glasgow, Scotland:**

Clan Tools (formerly Clan Lukas) is the British and French agent for among other products, Lukas rescue tools, and as such, holds approximately 70% of the British and Irish market.

Clan Tools not only provides the routine service of an agent: selling and repairing tools, but also provides a course of instruction for customers in the basics of tool maintenance, fault finding and trouble shooting. The course also includes tool stripping and seal replacement on the range of Lukas rescue tools. The purpose of this course, in which I participated, is not to replace their service department, but to give the end user a better understanding of the operation of rescue tools. It is also intended to enable rescue service personnel to accurately identify whether a reported fault truly exists, and if so what the problem is, before despatching the tools for repair.

The course includes a reference manual complete with overhead transparencies for training other personnel. The information I have gleaned has the potential to develop a similar training package, with the assistance of the Australian agent for Lukas.

Discussions throughout the course revealed the following technical tips:

All seals on moving parts in Lukas tools consist of a fibre washer, against the moving part, backed up by a rubber 'O' ring.

The new range of Lukas hand pumps (either single or double acting) do not require to be operated in an upright or elevated position to avoid air leaks, because they are not a closed system. That is, they should be operated with cap open (loose) to vent air. The new range of hand pumps have an internal pick up tube at the end of the pump reservoir, designed to ensure no air enters the system.

Paring tips for use with spreaders to tear sheet metal, can also be used, if reversed, to assist in crushing operations on wide pillars, prior to a cut.

The Lukas pedal cutter, like a number of others on the market is a single acting, spring return design, with the blade fitted into a 'C' shaped housing. This allows the job to be gripped between one moving and one fixed blade. The recommended method of operation for such tools is to cut along the long axis, as tests have shown that twisting can occur along the short axis of the job to be cut.

Lukas have produced a diesel powered hydraulic pump, for use near environments requiring intrinsically safe equipment.

The majority of the information gleaned from Clan Tools is of a practical nature relating to the 'Hands on' maintenance and fault finding of the tools.

Fluid Mechanics - The Technical Aspects of Hydraulic Rescue Tools:

As a result of visits to Lukas and Clan Tools, I have been able to enhance my understanding of the design and function of their hydraulic rescue tools.

All Lukas tools are built with an internal safety relief valve. If the pressure of hydraulic fluid builds up to an unsafe level, this valve opens. The valve is fitted on the closing or retraction side of the piston only, because the reduced operating surface area of the piston requires a higher working pressure for the same force output (Figure 10.4). The reason for this is that the net force to move the piston in the cylinder, and hence the tool arms or cutting blades, is derived from the pressure applied to the surface area of the piston exposed, that is:

$$\text{Force} = \text{Pressure} \times \text{Area} \quad (F = P \times A)$$

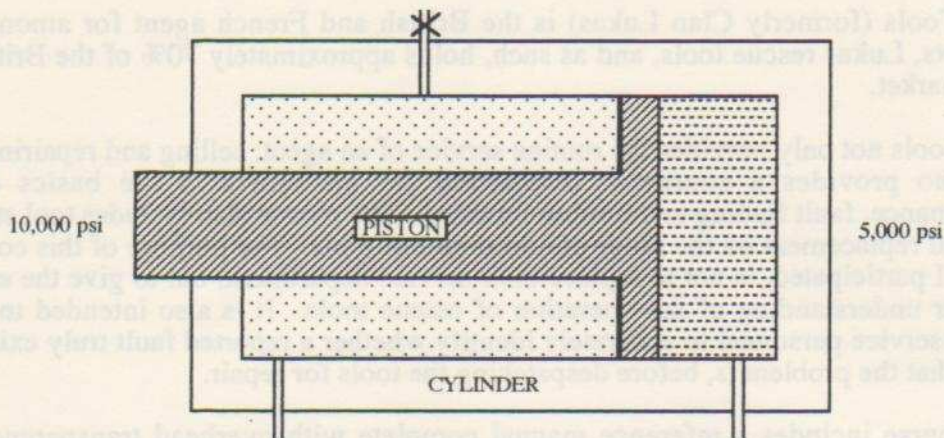

Figure 10.4: Cross section of Lukas piston/cylinder configuration.

So if no net movement occurs due to either an obstruction, or an inadvertent continued application of the tool once it has reached its fully closed position, the pressure will start to build. That is, force will be equal on both sides of the piston, but pressure will build if the control switch/valve is maintained in the 'On' position. Once the tool is in neutral, this pressure is restricted to just one side of the tool. For this reason, the use of tools in a series link by hoses is not recommended by Lukas.

In a series operation situation, such as is used by other manufacturers, the pressure generated by a pump in order to drive the first tool in such a series would be translated via the return hose, to the next tool when it is operated. So, if tool one remains switched 'on' under load, the pressure build up then translates down the series line to the next tool. Once again if tool two remains open under load, the same applies. The working pressure applied to the third tool, under these conditions, is likely to be so high that the safety valve will operate. If no safety valve is present, the seals between various component parts of the tool will be compromised and may start to leak (See Figure 10.5).

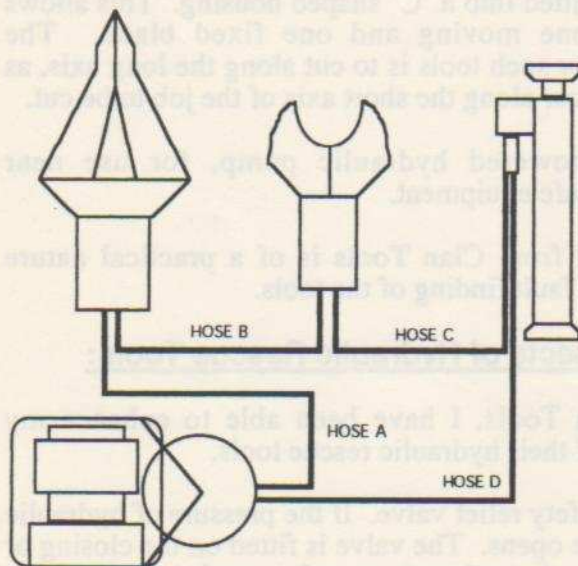

Figure 10.5: In this system, Hose A supplies hydraulic fluid to all tools. For each tool, the pump only applies working pressure, when that tool's control valve is 'on', whether to open or close the tool.

If the spreader's valve remains on after a tool closing operation is complete (ie. no net movement), pressure remains high in the return line (Hoses B, C & D). If the cutter is then operated at the same time, it is immediately exposed to the higher pressure generated by the spreader, since the cutters supply line is via hoses A & B. If both the cutter and spreader remain open at end of a tool close operation, the doubly high output pressure is fed to the ram through its supply hose C, thus creating the potential for seal and tool failure, if no safety valve is fitted.

Several manufacturers have overcome this problem in different ways. Hurst uses a splitter manifold, resulting in tools being connected in series, but uses heavier duty piston and cylinder construction, as well as higher pressure rated seals. The trade off for this is a lower power for weight ratio. Most other manufacturers produce pumps with capacity for two tools and a control valve to select which tool is being used. This ensures that the pressure build up in one tool is not transferred to the other. Amkus and Weber have taken this a stage further by offering a control valve as a remote extension, allowing it to be placed near the tools rather than fixed to the hydraulic pump. Amkus also offer a pump capable of driving four tools, once again with a control valve to choose.

Summary:

Visiting the manufacturing plants and agents provided a valuable insight into tool design and development.

The use of air bag equipment, both high and low pressure, is without doubt becoming more prolific within the rescue arena. This combined with its extensive use in industry, should prompt the question of the need for testing and regulation of use in this country. While it is fervently hoped that there will never be an accident or failure of such equipment in a rescue situation, given the nature of such an environment, the potential most certainly exists. Discussions with the Victorian Occupational Health and Safety Authority have revealed that at this time, high pressure air bags are not classified as pressure vessels, nor is there any requirement for routine testing of the equipment, provided the manufacturers specifications for maintenance, use and storage are adhered to. Given this, the only responsibility of any agency, operating such equipment, would appear to be, to ensure that such manufacturer's standards are maintained.

Visits to hydraulic tool manufacturers proved very valuable. Information was gained in various areas including the design and manufacture of the tools, as well as the application of the tools both in the road rescue setting and other rescue fields. Probably the most outstanding consideration in the manufacturing arena today is the power to weight ratio of such tools. It would appear, from the two plant visits I undertook, that the development of lighter tools is a priority, to satisfy the rapid response (*or intervention*) need in the market place. Hopefully this technology will not overly compromise tool power when reducing weight and size, but will in fact make the tools more efficient in this area. Similarly the question must be asked 'Where is the end point in development in this area?', with Lukas contemplating a rapid response system capable of being operated from a motorbike!

The basic course on tool design, trouble shooting, fault finding and maintenance will prove useful as the basis of a training program for rescue service personnel. Such information will 'reduce down' time and phantom faults creating problems. Such a training program will give the operator a better understanding of how the tool works, its internal safety features and potential for failure. This, hopefully, will ensure that the tools are used to their best advantage in a rescue setting.

HYDRAULIC RESCUE TOOL STANDARDS

Introduction:

Discussions with the hydraulic tool manufacturers revealed that much work has been carried out in both Germany and France to develop national standards, which are similar to those issued by the Standards Association of Australia (SAA), in relation to hydraulic tools. The French have also undertaken a scientific study and comparison of the various tools in the market place, as part of a testing process for compliance with their standard.

German Standard:

In Germany, the Technical Supervisory Committee or TÜV represents the equivalent of the combined capabilities of the SAA and National Accreditation and Testing Authority (NATA). That is, not only do they define the standards, but they also certify an organisation or item meets the relevant standard. The TÜV is responsible for the release and management of Deutsche Industrie Norm (DIN) [German Industrial Standards], which apply to many industries and professions.

The DIN relating to hydraulic tools defines certain criteria for the design and performance of the rescue tools. The history of development of the DIN, is such that the standards were written, after the tools had been available for some years. This is reflected in the standards to some degree, by their 'Middle of the road' requirements. That is, the standards have been designed to include the specifications of most tools produced by most manufacturers, without deliberately excluding any particular tool or company. This, in the eyes of many Germans in the industry (in both the sales and usage areas) appears to lower their value, as a standard, somewhat.

Should a tool not meet the DIN criteria then it does not receive TÜV approval. This has implications beyond just 'Rubber stamping' the tool and its manufacturer. In Germany, government and semi-government bodies receive a 'Top up' in their budget for capital expenditure that is in accordance with preferred government standards. Therefore, if a rescue service buys a tool that complies with the DIN, subject to approval, they will be reimbursed. The implications of this go further. At this point, no standard exists for combination tools, therefore, theoretically no such tools can be sold in Germany. Many of these tools, however, comply with the cutter DIN, and as a result a number of German rescue services are buying 'Cutters' on a 2:1 ratio to Spreaders to allow the combination tools to be incorporated into their kit.

The DIN defines requirements for spreaders, cutters and power packs. From a design perspective, the tools must have a 'Dead man' control valve, and must operate on a maximum hydraulic fluid pressure of 630 bar (9200 psi), with a safety valve release pressure of 820 bar (12000 psi). Other design specifications include:

- Maximum tool dimensions and weight
- Minimum opening distance
- Minimum closing distance (Spreader only - i.e. minimum displacement on a closing manoeuvre)
- Carry handle and frame requirements (Power packs only).

Performance criteria defined by the DIN include:

- Minimum force at the tips required to open a tool (Spreader only)
- Minimum force at the tips required to close a tool
- Maximum opening time (Spreader only)
- Maximum closing time.

French Standard:

In France, the Association Française de Normalisation (AFNOR) [French Standards Board] are responsible for the production of Normes Françaises (NF) [French Standards], which are again similar to those produced by SAA. The NF relating to hydraulic tools, despite also having been written as recently as October 1989, appears to be somewhat more rigorous in its approach to design and performance requirements than the DIN. The NF not only defines design and performance characteristics for the tools, but also the necessary test methodologies to ensure the tools are properly evaluated against the standard. Despite this, the NF only addresses double acting spreaders, cutters and combination tools (by combining the spreading and cutting standards). It does not assess rams. It does, however, include both motorised and hand operated pumps. AFNOR boasts that at the time of publication in 1989, no similar standard existed anywhere in the world.

Criteria:

The NF defines a range of 15 classes for spreaders, based on the minimum force¹ required to move the arms/jaws of the tool, as measured at the tips. Each class being defined as a 10 kN window from 10 kN through to 160 kN. For example, a tool with a measured minimum force of 37 kN would be categorised as either a cutter or spreader class 30. Once this classification has been identified using a testing rig, all other criteria are applied, based on the result. Two classes are defined for cutters, based on their opening distance, the point of measurement of which varies with the shape of the blades.

Some criteria are dependent on classification:

Spreaders:

- Minimum total opening distance (ie. maximum spread must be greater than a specified value)
- Maximum distance between tip and chain fixing point
- Weight (with and without accessories, eg: chain holding tips)
- Opening and closing times (from extreme points of travel)

¹ The force generated by a hydraulic rescue tool varies throughout its operating range, from fully closed to fully open. The minimum value across the tool's operating range is that used to classify the tool.

Cutters:
Weight

Other criteria are independent of classification:

Physical dimensions for all tools and motorised pumps
Weight distribution between handles (70-80% must be on the forward handle)
Weight for motorised and hand operated pumps
A 'Dead man' control switch must be mounted on the tool
Hydraulic hose couplings requirements including dust caps attached
Hydraulic hoses capabilities and conformance to relevant NF
Pump and tool systems must include a safety valve design to operate at 110% of normal working pressure
Hydraulic fluid characteristics must be satisfied
Tool arms/jaws must easily be interchanged, but not capable of accidental detachment
In a case of sudden pressure loss, tools must be self-sealing so that load is maintained

Spreaders:

Minimum closing force must be at least 80% of opening force

Cutters:

Class of cutting capability²
Opening and closing times³
Rotational twist force on cutting must not exceed 240 N (24 kg)

Motorised Pumps:

All pumps must be capable of starting after a 90° 'Tip over' and immediate righting
Electrically driven pumps must conform to the relevant electric NF

Hand Pumps:

Working pressure must be achieved with an exertion of no more than 350 N (35 kg) on the handle

Testing:

For testing purposes, tools must be supplied complete with all accessories. All measurements are made several times and must be within specified accuracies and environmental conditions. Each testing procedure is detailed to ensure that tool's compliance or otherwise is determined correctly. This bank of tests includes measurement of:

Opening and closing times
Spreader opening and closing forces
Spreader holding pressure⁴
Spreader overload pressure.

² Six classes of cutting capability are defined (A-F), each being progressively more difficult to achieve. These classes require the tool to be able to cut through various thickness of steel bar, flat plate, hollow tube, square and rectangular section steel.

³ This is independent of tool class for cutters.

⁴ This test involves simulating a hose burst and measuring the amount of closure of the spreader arms. The NF accepts less than 5% of the maximum opening distance.

Test are also conducted on:

- Cutters capability and endurance⁵
- Hydraulic pump and system cold (-20°C) starting ability
- Hydraulic pump and system endurance (1000 cycles of a calculated load is applied to a ram)

Combination tools are tested under the same specifications, applying both the spreader and cutter values accordingly. All tools and pumps must be marked, in French, with details of the manufacturer, the model and serial number of the tools, the year of manufacture and the maximum working pressure. Under the NF requirements, tools must also be supplied with a full written manual, detailing operating instructions, basic maintenance checks and a guarantee of both workmanship and the availability of spare parts for at least 10 years.

Tool Comparison by Brand:

Following the development of the Norme Française described above, Commander Douet of the French Federal Technical Commission (FTC) undertook a comparative study of eight manufacturers' tools against the standard. All were invited to supply a spreader, cutter, combination tool and pump, complete with all accessories for the test. They were also invited to have representatives present during the testing process.

The following manufacturers participated to varying degrees⁶:

| | |
|---|----------------------------------|
| Amkus (2 spreaders and a cutter) | Holmatro |
| Bemaex/Zumro (2 spreaders and a cutter) | Hurst |
| Lukas | Sides (2 spreaders and a cutter) |
| Gallego (2 spreaders and a cutter) | Weber |

Spreaders:

All tools submitted were initially classified in accordance with the NF. Four tools could not be classified:

- Amkus M 30 D due to a fracture of the arm during force tests;
- Amkus M 30 CX and Gallego GJ 11 because the chain fixing point was outside that specified by the NF; and
- Bemaex MDS 31 due to a hydraulic fluid leak.

Opening and closing speeds were measured next. This revealed that all tools met the standard, based on their earlier classification except the two Amkus spreaders, which were well outside the maximum allowable for any classification, and the Gallego spreader, which was outside the presumed class, had it passed the initial testing phase. Clearly, opening and closing times are dependent on the type of pump being used to drive the system. As a result, the Commission elected not to include these times in the approval/registration process.

⁵ 60 cuts are made across the 6 different classes of material. The blades are then assessed against new ones for sharpness. Ability to sharpen the blades is also noted.

⁶ All tools were supplied unless otherwise stated.

The final test conducted on the spreaders was a load and overload test. This test is designed to show how a tool will cope with:

- holding a fixed load within its safe working load (The tool should not creep under this load);
- holding the same load with a simulated burst hose (Same conditions apply); and
- holding the same load for 30 minutes (Creep should be limited to less than 5% of the total opening distance).

The same conditions were applied for the overload test which is set at 1.5 times the safe working load of the tool, except creep after 30 minutes must be less than 10mm.

In this case, all tools passed, except those which failed the earlier opening and closing force tests (for the same reasons).

Cutters:

All tools were weighed and measured and found to comply with the NF requirements for their relevant classification. Next, all tools were subjected to tests of cutting performance and endurance, and then classified into one of the six categories defined by the NF. Opening and closing speeds as well as axial rotation force on cutting were also measured. As with the spreaders, times were not included in the registration process, as they were dependent on the pump being used. Once again, all tools were found to comply with the NF, with no problems noted following the 60 endurance cuts.

In his conclusion, Douet makes clear what he describes as 'The flagrant lack of professionalism in the approach of some manufacturers to their quality of production and presentation of tools'. He identified:

- 4 out 10 spreaders that could not be classified;*
- 3 tests had to be terminated because of tool failure; and*
- the published advertising/technical data, which is often succinct, is generally much over estimated.*

In view of the divergence of test results from some manufacturer's advertised specification, Douet warns purchasers to be careful when selecting tools and take full advantage of the NF and the compliance testing the FTC has conducted.

Discussion:

As a result of the tests carried out, the FTC identified that tool opening and closing times were pump dependent. Their minimum force measurement tests also allowed the construction of force vs opening distance graphs. While both of these factors have been excluded from the NF, they can provide useful data when choosing a tool and pump system either for purchase or use in the field. The advantages of faster moving tools are obvious, the force information is not so clear. Douet's tests found tool force vs opening performances fall into one of two categories, depicted by figure 11.1 below⁷.

As can be seen, in some cases, tool performance remains constant across its working range, while others either continue to increase (sometimes as much as three fold) as the opening distance increases, in an exponential manner.

⁷ The graphs reproduced here are not based on exact figure measured in the tests described. They are intended to be samples only.

Figure 11.1: Spreading Force Vs Opening Distance

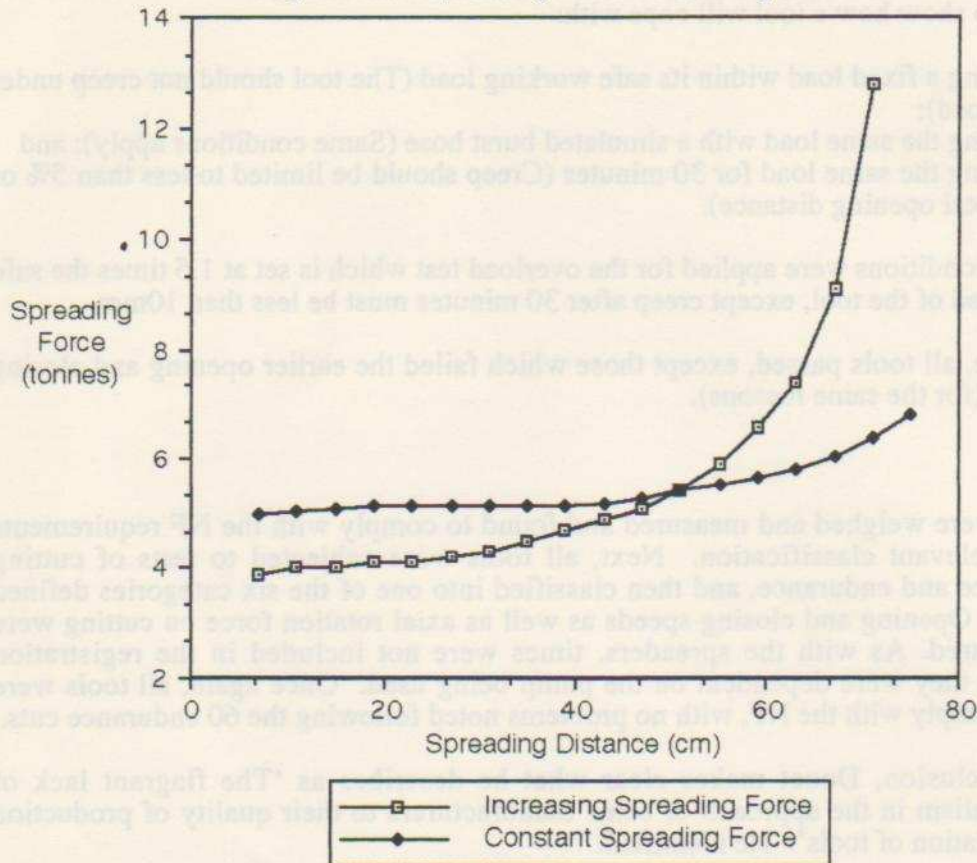

The cause of this variation in tool performance is not only related to manufacturing quality and pump performance. It is also dependent on tool design. Most spreaders currently on the market fall into one of three basic design categories, each of which has its own peculiar performance capabilities. The difference between them is the coupling between the tool's piston and arms, which can be:

- a cog arrangement (Figure 11.2);
- connecting levers (Figure 11.3); or
- direct attachment (Figure 11.4).

The relative location of the pivot point of the arms also has a significant bearing on the generation of force, as the distance from the piston versus the length of the arms defines the amount of mechanical advantage. The connecting lever arrangement as used by Holmatro, Hurst, Sides, Weber and Zumro has the capacity to more easily generate an increased spreading force as the tool opening increases. Whereas both the cog system, favoured by Amkus and Lukas, and direct connection system, used by Amkus, Hurst, Lukas and Weber, both provide a more stable performance profile across the operating spread.

Due to economic constraints, such information is only ever likely to be of importance during purchase. However, if money was no object and a choice of tools was available on every rescue tender, the rescuer who knows which tool performs best at a particular opening, is better equipped to more efficiently rescue the casualty.

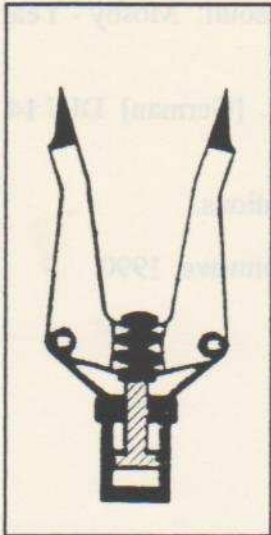

Figure 11.2: Cog driven spreaders. As the piston moves, the teeth mesh forcing the spreader arms to move.

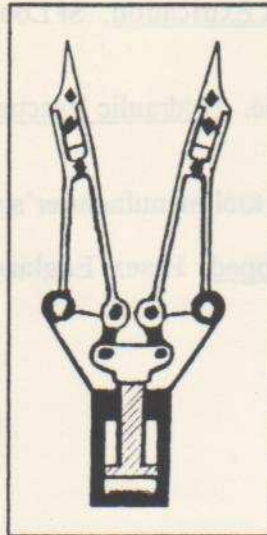

Figure 11.3: Lever connected spreaders. The levers allow an extra spreading width to be obtained as the piston extends.

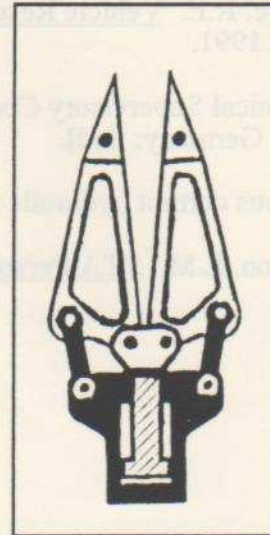

Figure 11.4: Directly connected spreaders. The laterally mounted levers provide another form of enhanced spreading capability.

Summary:

The tests conducted by the French have clearly highlighted the need for significant research about design and operation of hydraulic rescue tools, as well as a circumspect approach during the pre-purchase phase. Care, and liberal interpretation, must be taken when examining manufacturer's tool specifications. Adopting this attitude will ensure that the two age old contributing factors of cost and salesman promises are placed in an appropriate context in the light of technical facts.

The very need for both the formulation of national standards in Germany and France, and the subsequent compliance testing of hydraulic rescue tools, raises the question of the need for a similar process in Australia. Despite the fact that a large proportion of accredited Road Accident Rescue units in Victoria now have double acting hydraulic rescue tools, not every unit in Australia does. These two factors combined with the on going need to expand, update and improve resources as demands on rescue services increase, surely support this argument. Without doubt, any moves in this direction will have to be made with extreme care. Such action should be on a consultative basis with all rescue services being offered the opportunity to have input, as well as the relevant regulatory bodies such as the Occupational Health and Safety Authority.

References:

- Association Française de Normalisation. Double Acting Hydraulic Extrication Equipment. [French] French Standard NF S 61-571. Paris, France: French Standards Association, 1989.
- Douet, Cmdr. "Extrication". Le Sapeur Pompier. [French] No. 832, May 1992, pp. 243-7.
- Federal Technical Commission. Report of Tests on Extrication Equipment. [French] Paris, France: Department of the Interior, Directorate of Civil Defence, 1992

Moore, R.E. Vehicle Rescue and Extrication. St Louis, Missouri: Mosby - Year Book, 1991.

Technical Supervisory Committee. Hydraulic Rescue Tools. [German] DIN 14 571. Germany: [nd].

Various current hydraulic rescue tool manufacturer's publications.

Watson, L.M. RTA Persons Trapped. Essex, England: Greenwave, 1990.

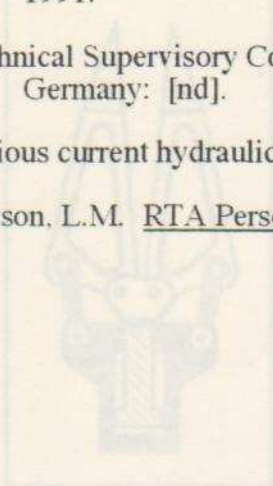

Figure 11.4: Directly connected spreader. The directly mounted levers provide another form of enhanced spreading capacity.

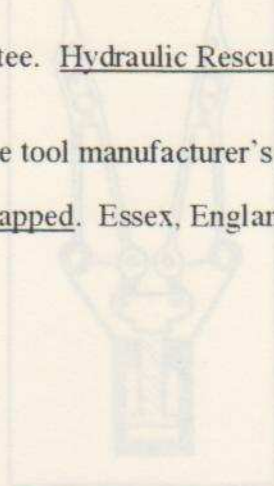

Figure 11.5: Lever connected spreader. The levers allow an extra spreading width to be obtained as the piston extends.

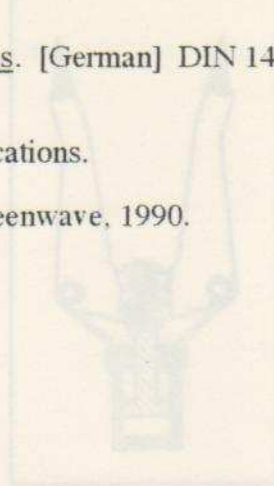

Figure 11.6: Long driven spreader. As the piston moves the shaft moves through both ends, allowing the spreader arms to move.

Summary

The tests conducted by the French have clearly highlighted the need for significant research about design and operation of hydraulic rescue tools, as well as a circumpect approach during the pre-purchase phase. Care, and liberal interpretation, must be taken when evaluating manufacturer's tool specifications. Adopting this attitude will ensure that the two age old contributing factors of cost and salesman promises are placed in an appropriate context in the light of technical facts.

The very need for both the formulation of national standards in Germany and France, and the subsequent compliance testing of hydraulic rescue tools, raises the question of the need for a similar process in Australia. Despite the fact that a large proportion of accredited Road Accident Rescue Units in Victoria now have double acting hydraulic rescue tools, not every unit in Australia does. These two factors combined with the on going need to expand, update and improve resources as demands on rescue services increase, surely support this argument. Without doubt, any moves in this direction will have to made with extreme care. Such action should be on a consistent basis with all rescue services being offered the opportunity to have input, as well as the relevant regulatory bodies such as the Commonwealth Health and Safety Authority.

References

- Association Française de Normalisation. Double Action Hydraulic Extrication. [unpublished]. French Standard NF S 01-271. Paris: France: French Standards Association, 1989.
- Dover, Omar. "Extrication." Le Rescue Pompier. [French]. No. 832, May 1992, pp. 248-7.
- Federal Technical Commission. Report of Tests on Extrication Equipment. [French]. Paris: France: Department of the Interior, Directorate of Civil Defence, 1992.

CONCLUSION

Introduction:

As with all scientific and technical studies that attempt to investigate or research one series of questions, invariably another series of equally interesting questions unfolds. This study tour has, without doubt, provided a perspective on road accident rescue techniques, training and equipment in Europe. It has also provided a benchmark for comparison of Australian, and in particular Victorian, standards in the world arena.

World Extrication '92:

The conference identified the apparent lack of legislation in Britain to address the Displan issue at both the coordination and combat levels. Despite, or perhaps because of this, organisations such as the Fire Service College and the Car Users Entrapment Extrication Society (CUEES) are committed, in their own very different ways, to improving the standard of response and the level of training of all personnel involved in major incidents.

The competition segment, both in content as well as intent, provided an insight into the attitudes and approaches of rescue personnel from around the world. The motivation of rescuers and the problem they have to contend with is the same all over the world, but the approach is as varied as the rescuers' background.

The incorporated trade display provided a valuable insight into the extensive array of tools and products available on the European market. While the overall selection available is somewhat greater than in Australia, there were very few items not seen in this country. The interface with the manufacturers available through such an event, however, enables constructive feedback from the operators to the makers to take place.

The information gained from the training packages presented has identified the need for all personnel to broaden their horizons with respect to these specialist areas. In the case of supplementary restraint systems (SRS), it has also highlighted the current lack of regulatory requirement for vehicles fitted with such systems to be identified, as exists for LPG powered vehicles. This means that as SRS's become more prolific on Australian roads, emergency service personnel will need to be more vigilant with initial scene assessments.

Rescue Service Visits:

Visits to the various rescue services of different countries revealed approaches to training and equipment that are as different as their cultures. The approach varies from the detailed modular course of the Dutch, through the multi level response system of the British, to the all most non-existent of the Parisian Fire Service.

Comparison of these Services against the Victorian Combined Emergency Services Accreditation Standard clearly indicates that Victorian Rescue Services are at least on a par with all those visited. The standard of equipment required in Victoria is generally greater than the mandatory requirements of any of the services visited. Most of the Services visited do, however, have a greater equipment base, to cope with the greater demand placed upon them. From a training perspective, the Combined Emergency Services Accreditation standard surpasses all of the services visited with the possible exception of the Dutch Fire/Rescue Service's training syllabus.

Companies and Equipment:

Discussions with manufacturers and distributors have revealed that the key push in the industry, today, is in the area of power for weight ratio with hydraulic tools. Tool manufacturers and designers appear to have locked into the need to provide smaller tools capable of being transported in smaller vehicles and used in confined spaces. This will hopefully result in an improved tool quality and gains from the purchasers point of view as the competition in the market place increases.

The hydraulic tool maintenance course has provided a greater understanding of tool design, construction and potential for failure. As this information is disseminated through training, it should result in fewer random or phantom faults occurring, as well as providing operators with greater confidence in their tools.

The question of national standards for both air bags and hydraulic tools in the rescue field has, without doubt, the potential to force major changes to current practices and the existing equipment of rescue services around the country. Despite this, the opportunity to ensure a common high standard of excellence in equipment used by such organisations should not be foregone. Such standards will not only produce a more concerted effort among rescue agencies to pursue equipment which performs to a known standard, but should also promote a more meticulous approach from manufacturers and distributors to ensure their product meets the standard.

Summary:

Examination of the status of training, equipment and techniques used by European Rescue Services has revealed that the Victorian Combined Emergency Services Accreditation standard is on an equal footing to any of the standards employed by the Services visited. Despite this, there is much to be learned from the European Rescue Services and tool manufacturers in a number of areas. This study tour provided valuable information in areas such as:

- Heavy vehicle rescue techniques;
- Supplementary restraint systems;
- Hydraulic rescue tool design, construction and fault finding; and
- National standards applied to hydraulic and pneumatic rescue tools.

Taking a leading role in collating and disseminating such information on new ideas and innovations is CUEES. The concept of such an inter-agency society of personnel interested in rescue is invaluable to ensure that information exchange between services across the country and internationally occurs. The British and World experience has shown that establishment of such an organisation in Australia will facilitate such a process, as well as providing a link to the rest of the world, from which all rescue personnel can benefit. Such an organisation should be supported and facilitated at the earliest possible opportunity.

I am most grateful to the Combined Emergency Services Foundation for their sponsorship. My thanks, also, to the following individuals and groups for their invaluable assistance and support:

Mr Gordon Hamilton and staff of Clan Tools and Plant;
The staff of the Fire Service College, Road Traffic Accident School;
The staff Vepro and Lukas;
The staff of the various Emergency Services I visited;
Mr Mike Akers and the members of CUEES; and
Mr David Bellairs of Power Team Australia.

As a result of this study, a link has been established to a worldwide circle of professional colleagues. Perhaps the most valuable lesson learned is that regardless of cultural background, political belief or even language, there is a worldwide fraternity that extends to all personnel in the rescue field. This stretches beyond just a similar professional interest, down to a common motivational desire to help other people in the most effective and efficient way possible.

PART FOUR:

ANNEXES

**BRITISH NATIONAL
HEALTH SYSTEM****MEDICAL OFFICER APPOINTMENTS
FOR A MAJOR INCIDENT**

| | |
|-------------------------------|---|
| Coordinating Medical Officer: | A senior hospital doctor, who will remain at the hospital and form the link from the site. |
| Medical Incident Officer: | The senior doctor at the scene of the incident who, through the Coordinating Medical Officer at the hospital, can call on any of the resources of the British National Health Service (NHS). |
| Site Medical Officer: | This person is responsible for the clinical aspects at the scene, or part of the scene if it is spread over a large area. This doctor must maintain a management role and not allow himself to become involved in patient treatment. |
| Triage Medical Officer: | The role of this doctor is to identify which patients will derive most benefit from medical treatment. That is, to give the highest priority to those casualties who will only survive if treated. In the performance of this task, the disaster site must not be relocated to the hospital, by simply moving all casualties. |
| Treatment Medical Officer: | This person leads a team of Nurses and Paramedics and is engaged in providing stabilising treatment. |

B

WORLD EXTRICATION '92 COMPETITION

JUDGES' EVALUATION FORM

EXTRICATION EVALUATION FORM

TEAM NUMBER: _____

| <u>COORDINATION & CONTROL</u> | <u>SCORE</u> | <u>COMMENTS</u> |
|---------------------------------------|--------------|-----------------|
| 1. <u>Size-up/Evaluation</u> | 1-15 | |
| 2. <u>Officer Control</u> | 1-15 | |
| 3. SAFETY ASPECTS | | |
| <u>Rescue Team</u> | 1-15 | |
| <u>Patient</u> | 1-15 | |
| <u>Area</u> | 1-15 | |
| <u>Vehicle</u> | 1-15 | |
| 4. EXTRICATION TECHNIQUE | | |
| <u>Knowledge of Equipment</u> | 1-15 | |
| <u>Knowledge of Vehicle</u> | 1-15 | |
| 5. COMPLETION OF TASK | | |
| | 1-15 | |
| 6. SPEED | | |
| 7. COMMENTS | | |

TOTAL SCORE

JUDGES NAME: _____

C**BRITISH FIRE SERVICES****BASIC RESCUE
EQUIPMENT CARRIED**

NOTE: In each case the equipment lists are intended to reflect only the major items of equipment carried. The lists are not intended to detail every piece of kit a Service or particular appliance may carry.

ANNEX C.1**STRATHCLYDE FIRE SERVICE****ROAD RESCUE VEHICLE**

8000lb Electric Winch

Hand Tools: Bow Saw
Shovel
Pry Bar x 2
Bolt Cutters
Wood Hand Saw
Axe
Broom

Paraguard Stretcher

Generator

Portable lighting

Various electric leads

Petrol over Hydraulic Power Pack

Electric over Hydraulic Power Pack (Backup)

Double Acting¹ Spreader

Double Acting Cutter

Double Acting Hand Pump

Air Bag 40 tonne x 2

Air Cylinder (Similar to size F) x 4

Tirfor 5 tonne

Reciprocating Saw

Safety Cones

Strobe Lights

Wooden Blocks & Chocks

See Figure C.1.

¹ Double acting tools require hydraulic power to both open and close, unlike the more traditional hand operated tools which are spring operated to return to their ready position.



Figure C.1: Strathclyde Road Rescue Vehicle.

STRATHCLYDE FIRE SERVICE

ANNEX C.2

HEAVY RESCUE VEHICLE

- Heavy Duty Jacks, 60t x 2 & 100t x 2
- High Pressure Air Bags, 60t x 3
- Double Acting Spreaders x 6
- Double Acting Cutters x 6
- Double Acting Rams x 6 (2 of each size)
- Double Acting Hand Pumps x 3
- Petrol over Hydraulic Pumps x 3
- Chainsaws various
- Generators x 4
- Telescopic light stands and lights x 4
- Portable lighting and lanterns
- Hammer Drills x 3
- Reciprocating Saws x 3
- Tirfors x 3
- Thermal Lance
- BA cylinders primarily for air tools
- Stokes Litters x 2

Roll up Stretchers x 4
Riot Shields for casualty protection
Full body harnesses and life lines x 2
Various other ropes
Axle stands 10t x 4
Tool kit - mechanical x 6
Hand trolleys for transporting equipment x 3

Various SWR strops and slings stored in old tyre cases for use with tirdors, etc.
Inflatable Air Tent for use as a casualty clearing station, or welfare shelter
A range of assorted Acrow Props and wooden blocks for shoring

A range of heavy duty hand tools including:

Large bolt cutters x 4
Large pry bars x 6
Short handled shovels for working in confined spaces x 6
Hooligan Tools x 6

A range of protective clothing in sets of six including:

Helmets with ears muffs and clear visors for general work
Helmets with darkened face shields for use with the Thermal Lance (two only)
Chainsaw chaps
Splash suits

The vehicle is also equipped with:

A hydraulic platform for loading and unloading heavy equipment;
A full work bench for on site repairs, cleaning and make up of tools, this includes a small stock of spare parts and fuel;
A deployment board to track the issue and return of all tools; and
Hand trucks to transport equipment to and from vehicle.

See Figure C.2.

ANNEX C.3

GREATER MANCHESTER COUNCIL FIRE SERVICE

GENERAL DUTY PUMPERS

A range of hand tools
Hooligan tool
Various blocks and wedges
Double acting hydraulic combination tool
Petrol over Hydraulic pump
Double acting hand pump
Hand operated hydraulic kit (similar to Porta Power)
Air chisel
Air bag 12t x 1
Air operated reciprocating (Cengar) saw

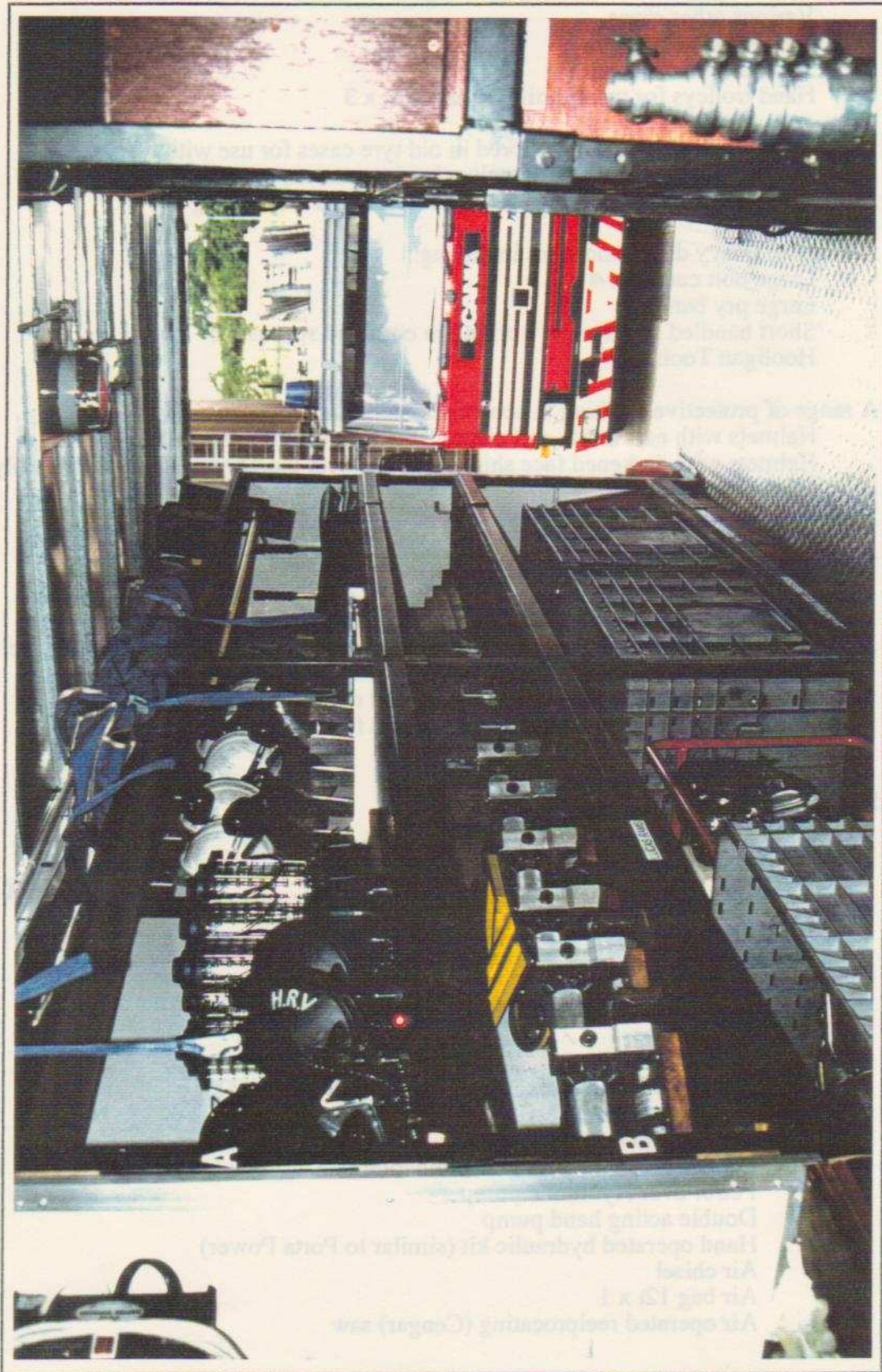

Figure C-2: Strathclyde Heavy Rescue Vehicle.

ANNEX C.4**MERSEYSIDE FIRE SERVICE****GENERAL DUTY PUMPER**

Petrol over hydraulic pump
Double acting combination tool
Double acting ram
Double acting hand pump
Assorted hand tools

ANNEX C.5**MERSEYSIDE FIRE SERVICE****EMERGENCY/CONTROL TENDER**

Oxy-acetylene cutting gear
Lighting, both portable and fixed
Hand operated hydraulic kit
Petrol driven hydraulic pump
Double acting spreader
Double acting cutter
Double acting hand pump
A set of shear legs
Tirfor 3 tonne
5 tonne hydraulic winch
Disc cutter
Various high pressure air bags
Assorted Hand tools
BA sets and cylinders
Generator both for lighting and Control unit power
Ballast pumping attachments for maintaining ships upright following fires
Radiation monitoring dosimeters and radiac digital monitors

D

ANNEX D.1

**CONTINENTAL
RESCUE SERVICES****BASIC RESCUE
EQUIPMENT CARRIED**

NOTE: In each case the equipment lists are intended to reflect only the major items of equipment carried. The lists are not intended to detail every piece of kit a Service or particular appliance may carry.

ANNEX D.1**PARIS FIRE BRIGADE****RESCUE VEHICLE**

PTO operated generator
 A range of hand tools
 9000lb electric winch
 Portable lighting x 3 stands (1000W each)
 Plasma cutter
 Electric over hydraulic power pack
 Double acting spreader
 Double acting rams x 2
 Double acting cutter
 Double acting hand pump
 Air bags 40t x 1 & 15t x 1
 Electric angle grinder/disc cutter
 Heavy duty bottle jacks x 2
 Tirfor 3 tonne
 Portable generator
 Electric extension cable x 200 metres
 Air mast with 1000W lighting attached
 Electric chain saw
 Electrical adaptors for use in the underground rail network

ANNEX D.2

BREDA FIRE SERVICE

HEAVY RESCUE VEHICLE

Hiab crane
Chainsaws
Assorted hand tools
Oxy-Acetylene torch
Portable generator
Portable lighting
PTO operated generator
Double acting spreader
Double acting cutter
Double acting hand pump
Petrol over hydraulic power pack
BA sets and gas suits
Heavy duty jacks
Tirfor
Disc cutter
Air bags - low and high pressure
Air bags - leak sealers
Intrinsically safe pumps for fuel spills
Porta power kit
Radiation monitoring equipment
Beryllium hand tools for use in a spark free environment

Breda Fire service also operate a module based system with a prime mover, which can deliver a variety of pods to a designated location.

ANNEX D.3

ERLANGEN CITY FIRE SERVICE

**RAPID RESPONSE ROAD
RESCUE VEHICLE**

Wooden blocks
Double acting spreader
Double acting cutter
Double acting ram
Double acting hand pump
Electric over hydraulic power pack
Double acting combination tool
Portable generator
Portable lighting and stands
Assorted hand tools
Fire extinguisher
Safety cones

ANNEX D.4**ERLANGEN CITY FIRE SERVICE****HEAVY SALVAGE/RESCUE VEHICLE**

Low pressure air bags
High pressure air bags
Foam concentrate
Intrinsically safe portable generator
PTO operated generator
Heavy duty lighting mast
Double acting spreader
Double acting cutter
Double acting ram
Double acting hand pump
Electric over hydraulic power pack
Electric winch - heavy duty
BA sets and spare cylinders
Chainsaws
Assorted hand tools
Fresh air ventilation fans
Wooden blocks
Tirfor
Trawalla type jacks
Inflatable rubber boat
Hand operated hydraulic kit
Stainless steel buckets for hazmat spills

This vehicle also carries a range of fire suppression and clean up equipment.

All bins and lockers are number coded and marked with international symbols denoting their contents.

